

螺帽絲攻

NUT TAPS



公司沿革

詮豐精密工具成立於西元1983年7月，主要以生產螺紋栓規、環規、螺紋切削工具為主，為確保公司產品之品質，從德國進口工具顯微鏡、萬能測長儀及校驗量具，用於檢驗產品之品質，並於每一件出廠產品附據檢驗合格證，並因此在工業界得以發展。因應各界的需求，本公司於西元1989年增設螺絲攻生產線；其生產螺絲攻及各種螺紋切削工具，欲精益求精，於西元1992年，成立電腦管理系統。於西元1998年5月通過TUV認證，提供最完美之產品來提供客戶的需求。除了依客戶的需求訂製特殊刀具，來解決客戶的各種加工問題及傳遞最新資訊外，同時對客戶的承諾就品質的保證，提供完整且專業的產品及各種服務。除此之外，於2010年成立校正實驗室，認證項目包含平行與錐度栓環規，並於2014年2月通過全國認證基金會(TAF)認證。提供業界最完美、最完善的優質服務及最高品質的產品。

INTRODUCTION

CHUAN HONG PRECISION TOOL MFG. CO., LTD was founded in July, 1983, specializing in manufacturing thread plug gage, thread ring gages, and thread cutting tools. To ensure high level of product quality, we imported precision tools like microscope, universal length measuring instrument and calibration instruments from Germany to examine the finished products. Each finished product comes with inspection certificate. To further improve product quality, computer system was implemented in 1992 to achieve computerized management. In addition, ISO quality system was implemented in 1997 and were certified for ISO9001 standard in May, 1998. We hold the belief that full employee participation in quality standard promotes high product quality which is the best way to service our customer.



目次

CONTENTS

螺帽絲攻(SNT) -----	P.01
Nut Tap (SNT)	
螺絲柄螺帽絲攻 (SNB) -----	P.04
Nut Tap (Coupler Type)	
導引螺帽絲攻(SBD) -----	P.07
Guide Nut Tap (Coupler Type)	
螺紋工具GH精度表 -----	P.09
Thread Cutting Tools GH Limits	
螺帽絲攻接管 (SD) -----	P.10
Coupler	
螺帽絲攻彎柄 (SN) -----	P.13
Bent Shank	
螺旋絲攻.先端絲攻(SFT.POT) -----	P.16
Spiral Flute Taps & Spiral Point Taps	
無削絲攻 (FT) -----	P.19
Forming Taps	
行星式小滾輪 -----	P.21
Thread Small Rolling Dies	
螺絲滾輪 (TR) -----	P.22
Thread Rolling Dies	
螺帽絲攻溝槽研磨機 -----	P.23
Tap Lapping Machine	
切削角測定儀 -----	P.24
Cutting Angle Measuring Instrument	
螺帽檢測儀 -----	P.25
OD Concentricity Measuring Instrument	
螺帽檢測規 -----	P.26
Concentricity Thread Plug Gauge	
螺帽內徑檢測規 -----	P.28
Concentricity Plug Gauge	
拉力測試棒 (BD) -----	P.30
Thread Pull Mandrel	
螺帽絲攻選別與故障排除 (參考資料) -----	P.31
Nut Tap & Question (Reference)	



詮豐精密工具股份有限公司 Chuan Hong precision tool MFG.CO.,LTD

螺帽絲攻 (SNT)M Nut Taps

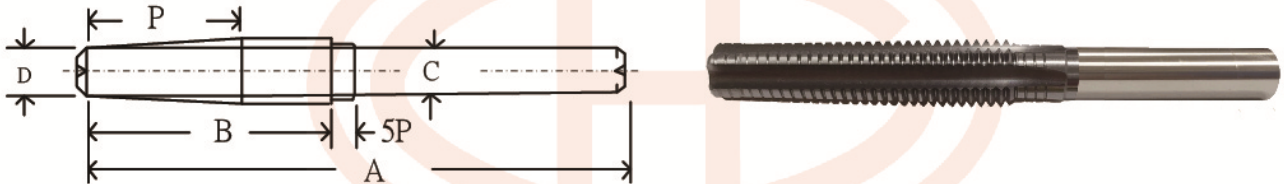

M 公制螺紋

單位: mm

規格 Specification	A 全長	B S45C	B SUS	CΦ 柄徑	P 食付	D 先端徑	GH 精度	S-45C直槽 TIN	SUS直槽 TACON
M 3 X 0.5	58	13.0	15.0	2.3	10.0	2.48	5,6,7		
M 4 X 0.7	58	18.2	21.0	3.0	13.0	3.27	5,6,7		
M 5 X 0.8	62	20.8	24.0	3.8	15.0	4.15	6,7,8		
M 6 X 1.0	67	26.0	30.0	4.5	20.0	4.95	6,7,8		
M 8 X 1.0	77	26.0	30.0	6.4	20.0	6.95	6,7,8		
M 8 X 1.25	77	32.5	37.5	6.1	24.0	6.70	7,8,9		
M 10 X 1.0	89	26.0	30.0	8.4	20.0	8.95	7,8,9		
M 10 X 1.25	89	32.5	37.5	8.1	24.0	8.70	7,8,9		
M 10 X 1.5	89	39.0	45.0	8.0	30.0	8.45	7,8,9		
M 12 X 1.25	102	52.0	37.5	10.0	24.0	10.70	7,8,9		
M 12 X 1.5	102	39.0	45.0	9.8	30.0	10.42	7,8,9		
M 12 X 1.75	102	52.0	52.5	9.5	35.0	10.15	8,9,10		
M 14 X 1.5	114	39.0	45.0	11.2	30.0	12.42	8,9,10		
M 14 X 2.0	114	52.0	60.0	11.2	39.0	11.90	8,9,10		
M 16 X 1.5	127	39.0	45.0	13.1	30.0	14.42	8,9,10		
M 16 X 2.0	127	52.0	60.0	13.1	39.0	13.90	8,9,10		
M 18 X 1.5	133	39.0	45.0	15.0	30.0	16.40	8,9,10		
M 18 X 2.0	133	52.0	60.0	15.0	39.0	15.90	8,9,10		
M 18 X 2.5	133	65.0	75.0	14.5	50.0	15.40	8,9,10		
M 20 X 1.5	133	39.0	45.0	16.5	30.0	18.40	7,8,9		
M 20 X 2.0	133	52.0	60.0	16.5	39.0	17.90	8,9,10		
M 20 X 2.5	133	65.0	75.0	16.5	50.0	17.40	8,9,10		
M 22 X 2.0	146	52.0	60.0	19.0	39.0	19.90	8,9,10		
M 22 X 2.5	146	65.0	75.0	17.0	50.0	19.40	8,9,10		
M 24 X 1.5	165	39.0	45.0	21.5	30.0	22.40	8,9,10		
M 24 X 2.0	165	52.0	60.0	20.0	39.0	21.90	8,9,10		
M 24 X 3.0	165	78.0	90.0	18.5	60.0	20.90	9,10,11		
M 27 X 3.0	190	78.0	90.0	21.5	60.0	23.90	9,10,11		
M 30 X 3.5	210	91.0	105.0	25.0	69.0	26.35	9,10,11		

※有●者備有庫存。
● means we have the item in stock.

※無庫存及特殊品，歡迎訂製。
No stock or special specifications are available on request.



詮豐精密工具股份有限公司 Chuan Hong precision tool MFG.CO.,LTD

螺帽絲攻 (SNT)UNC Nut Taps

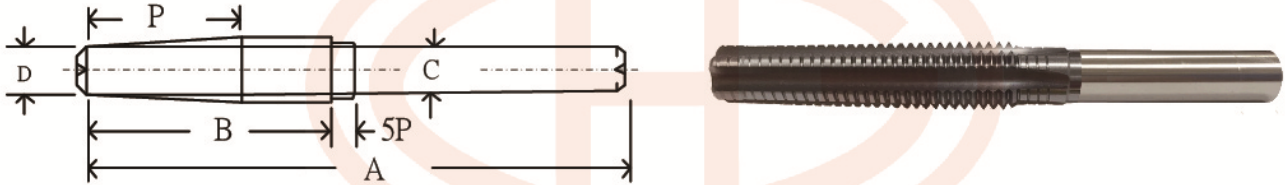

UNC 美制粗牙螺紋

單位：mm

規格 Specification	A 全長	B S45C	B SUS	CΦ 柄徑	P 食付	D 先端徑	GH 精度	S-45C直槽 TIN	SUS直槽 TACON
NO.4 - 40 UNC	58	16.5	19.1	2.0	12.4	2.18	5,6,7		
NO.5 - 40 UNC	58	16.5	19.1	2.2	12.4	2.51	5,6,7		
NO.6 - 32 UNC	60	20.6	23.8	2.4	15.5	2.68	5,6,7		
NO.8 - 32 UNC	60	20.6	23.8	3.1	15.5	3.34	5,6,7		
NO.10 - 24 UNC	69	27.5	31.7	3.4	20.6	3.74	5,6,7		
NO.12 - 24 UNC	69	27.5	31.7	4.0	20.6	4.40	5,6,7		
1/4" - 20 UNC	72	33.0	38.1	4.5	24.8	5.05	6,7,8		
5/16" - 18 UNC	77	36.7	42.3	6.0	27.5	6.48	6,7,8		
3/8" - 16 UNC	89	41.3	47.6	7.3	31.0	7.88	7,8,9		
7/16" - 14 UNC	102	47.2	54.4	8.6	35.4	9.19	7,8,9		
1/2" - 13 UNC	102	50.8	58.6	10.0	38.1	10.65	8,9,10		
9/16" - 12 UNC	114	55.0	63.5	11.0	41.3	12.07	8,9,10		
5/8" - 11 UNC	127	60.0	69.3	12.8	45.0	13.46	8,9,10		
3/4" - 10 UNC	133	66.0	76.2	15.0	49.5	16.41	9,10,11		
7/8" - 9 UNC	146	73.4	84.7	17.0	55.0	19.30	9,10,11		
1" - 8 UNC	165	82.6	95.3	20.0	62.0	22.12	9,10,11		

※有●者備有庫存。
● means we have the item in stock.

※無庫存及特殊品，歡迎訂製。
No stock or special specifications are available on request.



詮豐精密工具股份有限公司 Chuan Hong precision tool MFG.CO.,LTD

螺帽絲攻 (SNT) UNF.W Nut Taps

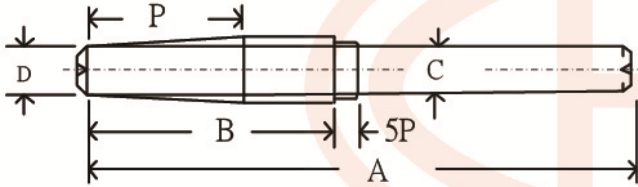

UNF 美制細牙螺紋

單位: mm

規格 Specification	A 全長	B S45C	B SUS	CΦ 柄徑	P 食付	D 先端徑	GH 精度	S-45C直槽 TIN	SUS直槽 TACON
NO.5 - 44 UNF	58	15.0	17.3	2.2	11.3	2.54	4,5,6		
NO.6 - 40 UNF	58	16.5	19.1	2.6	12.4	2.82	4,5,6		
NO.8 - 36 UNF	60	18.3	21.2	3.1	13.7	3.41	4,5,6		
NO.12 - 32 UNF	69	20.6	23.8	3.7	15.5	4.00	5,6,7		
NO.12 - 28 UNF	69	23.6	27.2	4.2	17.7	4.55	5,6,7		
1/4" - 28 UNF	72	23.6	27.2	5.0	17.7	5.38	5,6,7		
5/16" - 24 UNF	77	27.5	31.7	6.3	20.6	6.83	5,6,7		
3/8" - 24UNF	89	27.5	31.7	8.0	20.6	8.40	6,7,8		
7/16" - 20 UNF	102	33.0	38.1	9.3	24.8	9.74	7,8,9		
1/2" - 20 UNF	102	33.0	38.1	10.9	24.8	11.33	7,8,9		
9/16" - 18 UNF	114	36.7	42.3	11.4	27.5	12.78	8,9,10		
5/8" - 18UNF	127	36.7	42.3	13.1	27.5	14.36	8,9,10		
3/4" - 16 UNF	133	41.3	47.6	15.0	31.0	17.36	8,9,10		
7/8" - 14 UNF	146	47.2	54.4	18.5	35.4	20.31	8,9,10		
1" - 12 UNF	165	55.5	63.5	21.0	41.3	23.18	8,9,10		

W 英制螺紋

單位: mm

規格 Specification	A 全長	B S45C	B SUS	CΦ 柄徑	P 食付	D 先端徑	GH 精度	S-45C直槽 TIN	SUS直槽 TACON
W 3/16" - 24	69	27.5	31.7	3.2	20.6	3.65	5,6,7		
W 1/4" - 20	72	33.0	38.1	4.5	24.8	5.03	5,6,7		
W 5/16"-18	77	36.7	42.3	6.0	27.5	6.48	5,6,7		
W 3/8"-16	89	41.3	47.6	7.3	31.0	7.87	6,7,8		
W 7/16" - 14	102	47.2	54.4	8.6	35.4	9.21	6,7,8		
W 1/2" - 12	102	55.0	63.5	9.5	41.3	10.48	7,8,9		
W 9/16" - 12	114	55.0	63.5	10.5	41.3	12.07	7,8,9		
W 5/8" - 11	127	60.0	69.3	12.8	45.0	13.47	8,9,10		
W 3/4" - 10	133	66.0	76.2	15.0	49.5	16.41	9,10,10		
W 7/8" - 9	146	73.4	84.7	17.0	55.0	19.30	9,10,11		
W 1" - 8	165	82.6	95.3	20.0	62.0	22.13	9,10,11		

※有●者備有庫存。
● means we have the item in stock.

※無庫存及特殊品，歡迎訂製。
No stock or special specifications are available on request.



詮豐精密工具股份有限公司 Chuan Hong precision tool MFG.CO.,LTD

螺絲柄螺帽絲攻 (SNB)M Nut Tap (Coupler Type)

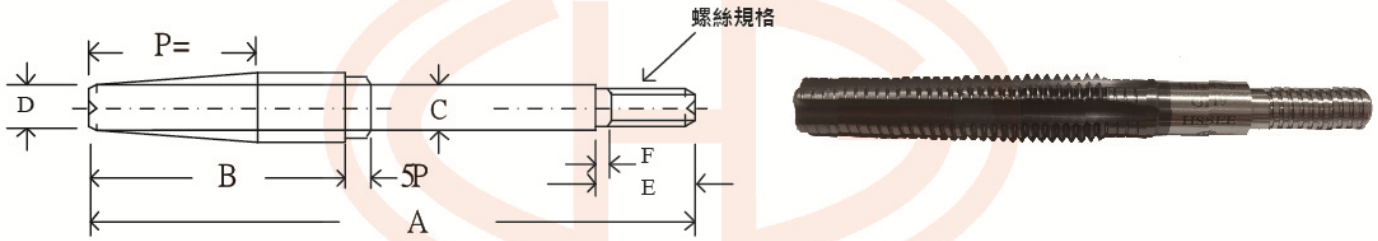

M 公制螺紋

單位: mm

規格 Specification	A 全長	B S45C	B SUS	CΦ 柄徑	D 先端徑	E	F	5P	螺絲規格 Screw Size	GH 精度	S-45C直槽 TIN	SUS直槽 TACON
M 6 X 1.0	67	26.0	30.0	4.5	4.95	15.0	1.5	5.0	R 3.5 P 1.5	6,7,8		
M 8 X 1.0	77	26.0	30.0	6.4	6.95	15.0	2.0	5.0	R 4.5 P 1.5	6,7,8		
M 8 X 1.25	77	32.5	37.5	6.1	6.70	15.0	2.0	6.3	R 5.0 P 1.5	7,8,9		
M 10 X 1.0	89	26.0	30.0	8.4	8.95	20.0	2.5	5.0	R 6.0 P 2.0	7,8,9		
M 10 X 1.25	89	32.5	37.5	8.1	8.70	20.0	2.5	6.3	R 6.0 P 2.0	7,8,9		
M 10 X 1.5	89	39.0	45.0	8.0	8.45	20.0	2.5	7.5	R 6.0 P 2.0	7,8,9		
M 12 X 1.0	102	26.0	30.0	10.4	10.95	25.0	3.0	5.0	R 8.0 P 2.0	7,8,9		
M 12 X 1.25	102	32.5	37.5	10.0	10.70	25.0	3.0	6.3	R 8.0 P 2.0	7,8,9		
M 12 X 1.5	102	39.0	45.0	9.8	10.42	25.0	3.0	7.5	R 7.5 P 2.0	7,8,9		
M 12 X 1.75	102	45.5	52.5	9.5	10.15	25.0	3.0	8.8	R 7.5 P 2.0	8,9,10		
M 14 X 1.0	114	26.0	30.0	12.4	12.95	25.0	3.0	5.0	R 9.0 P 2.0	7,8,9		
M 14 X 1.5	114	39.0	45.0	11.2	12.42	25.0	3.0	7.5	R 9.0 P 2.0	7,8,9		
M 14 X 2.0	114	52.0	60.0	11.2	11.90	25.0	3.0	8.8	R 9.0 P 2.0	8,9,10		
M 16 X 1.5	127	39.0	45.0	13.1	14.42	30.0	3.5	7.5	R 10.0 P 3.0	8,9,10		
M 16 X 2.0	127	52.0	60.0	13.1	13.90	30.0	3.5	10.0	R 10.0 P 3.0	8,9,10		
M 18 X 1.5	133	39.0	45.0	15.0	16.40	30.0	4.0	7.5	R 12.0 P 3.0	8,9,10		
M 18 X 2.0	133	52.0	60.0	15.0	15.90	30.0	4.0	10.0	R 12.0 P 3.0	8,9,10		
M 18 X 2.5	133	65.0	75.0	14.5	15.40	30.0	4.0	12.5	R 12.0 P 3.0	8,9,10		
M 20 X 1.5	133	39.0	45.0	16.5	18.40	30.0	4.0	7.5	R 13.0 P 3.0	8,9,10		
M 20 X 2.0	133	52.0	60.0	16.5	17.90	30.0	4.0	10.0	R 13.0 P 3.0	8,9,10		
M 20 X 2.5	133	65.0	75.0	16.5	17.40	30.0	4.0	12.5	R 13.0 P 3.0	8,9,10		
M 22 X 1.5	146	39.0	45.0	18.5	20.40	30.0	4.0	7.5	R 14.0 P 3.0	8,9,10		
M 22 X 2.0	146	52.0	60.0	19.0	19.90	30.0	4.0	10.0	R 16.0 P 3.0	8,9,10		
M 22 X 2.5	146	65.0	75.0	17.5	19.40	30.0	4.0	12.5	R 14.0 P 3.0	8,9,10		
M 24 X 1.5	165	39.0	45.0	21.5	22.40	35.0	5.0	7.5	R 16.0 P 3.0	8,9,10		
M 24 X 2.0	165	52.0	60.0	20.0	21.90	35.0	5.0	10.0	R 16.0 P 3.0	8,9,10		
M 24 X 3.0	165	78.0	90.0	18.5	20.90	35.0	5.0	15.0	R 16.0 P 3.0	9,10,11		
M 27 X 3.0	190	78.0	90.0	21.5	23.90	35.0	5.0	15.0	R 16.0 P 3.0	9,10,11		
M 30 X 3.5	210	91.0	105.0	25.0	26.35	35.0	5.0	17.5	R 18.0 P 3.0	9,10,11		

※有●者備有庫存。
● means we have the item in stock.

※無庫存及特殊品，歡迎訂製。
No stock or special specifications are available on request.



詮豐精密工具股份有限公司 Chuan Hong precision tool MFG.CO.,LTD

螺絲柄螺帽絲攻 (SNB) UNC.UNF Nut Tap (Coupler Type)

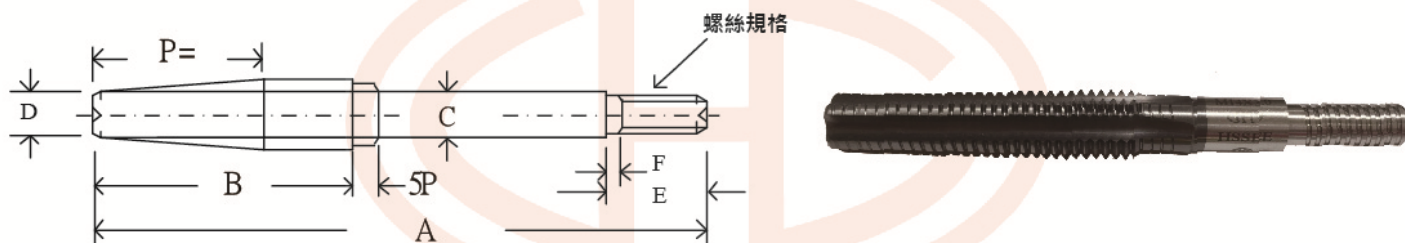

UNC 美制粗牙螺紋

單位: mm

規格 Specification	A 全長	B S45C	B SUS	CΦ 柄徑	D 先端徑	E	F	5P	螺絲規格 Screw Size	GH 精度	S-45C直槽 TIN	SUS直槽 TACON
1/4 - 20UNC	72	33.0	38.1	4.5	5.05	15.0	1.5	6.4	R 3.5 P 1.5	6,7,8		
5/16 - 18UNC	77	36.7	42.3	6.0	6.48	15.0	2.0	7.1	R 4.5 P 1.5	6,7,8		
3/8 - 16UNC	89	41.3	47.6	7.3	7.88	20.0	2.0	8.0	R 5.0 P 1.5	7,8,9		
7/16 - 14UNC	102	47.2	54.4	8.6	9.19	20.0	3.0	9.0	R 6.0 P 2.0	7,8,9		
1/2 - 13UNC	102	50.8	58.6	10.0	10.65	25.0	3.0	9.8	R 7.5 P 2.0	8,9,10		
9/16 - 12UNC	114	55.0	63.5	11.0	12.07	25.0	3.0	10.6	R 7.5 P 2.0	8,9,10		
5/8 - 11UNC	127	60.0	69.3	12.8	13.46	25.0	3.5	11.5	R 9.5 P 3.0	8,9,10		
3/4 - 10UNF	133	66.0	76.2	15.0	16.41	30.0	4.0	12.7	R12.0 P 3.0	9,10,11		
7/8 - 9UNC	146	73.4	84.7	17.0	19.30	30.0	4.5	14.1	R13.0 P 3.0	9,10,11		
1 - 8UNC	165	82.6	95.3	20.0	22.12	35.0	5.0	15.9	R16.0 P 3.0	9,10,11		

UNF 美制細牙螺紋

單位: mm

規格 Specification	A 全長	B S45C	B SUS	CΦ 柄徑	D 先端徑	E	F	5P	螺絲規格 Screw Size	GH 精度	S-45C直槽 TIN	SUS直槽 TACON
1/4 - 28UNF	72	23.6	27.2	5.0	5.38	15.0	1.5	4.5	R 3.5 P 1.5	5,6,7		
5/16 - 24UNF	77	27.5	31.7	6.3	6.83	15.0	2.0	5.3	R 4.5 P 1.5	5,6,7		
3/8 - 24 UNF	89	27.5	31.7	8.0	8.40	20.0	2.0	5.3	R 5.5 P 1.5	6,7,8		
7/16 - 20UNF	102	33.0	38.1	9.3	9.74	25.0	3.0	6.4	R 7.5 P 2.0	7,8,9		
1/2 - 20UNF	102	33.0	38.1	10.9	11.33	25.0	3.0	6.4	R 8.0 P 2.0	7,8,9		
9/16 - 18UNF	114	36.7	42.3	11.4	12.78	30.0	3.0	7.1	R 9.0 P 2.0	8,9,10		
5/8 - 18UNF	127	36.7	42.3	13.1	14.36	30.0	3.5	7.1	R10.0 P 3.0	8,9,10		
3/4 - 16UNF	133	41.3	47.6	15.0	17.36	30.0	4.0	8.0	R12.0 P 3.0	8,9,10		
7/8 - 14UNF	146	47.2	54.4	18.5	20.31	30.0	4.5	9.1	R16.0 P 3.0	8,9,10		
1 - 12UNF	165	55.5	63.5	21.0	23.18	35.0	5.0	10.6	R16.0 P 3.0	8,9,10		

※有●者備有庫存。
● means we have the item in stock.

※無庫存及特殊品，歡迎訂製。
No stock or special specifications are available on request.



詮豐精密工具股份有限公司 Chuan Hong precision tool MFG.CO.,LTD

螺絲柄螺帽絲攻 (SNB)BSW Nut Tap (Coupler Type)

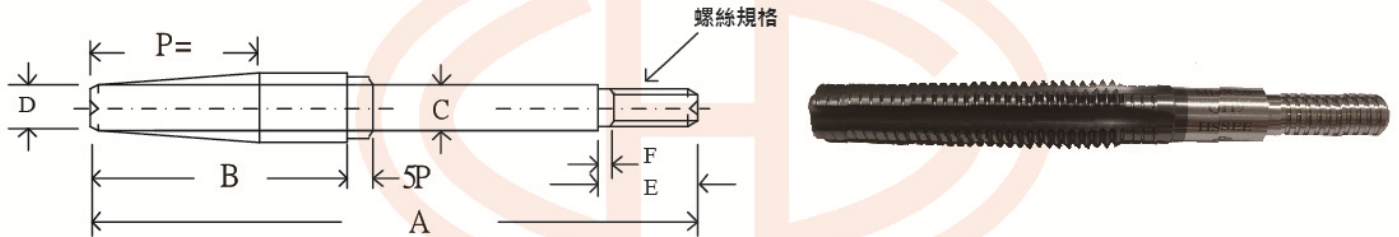

W 英制粗牙螺紋

單位: mm

規格 Specification	A 全長	B S45C	B SUS	CΦ 柄徑	D 先端徑	E	F	5P	螺絲規格 Screw Size	GH 精度	S-45C直槽 TIN	SUS直槽 TACON
W 1/4 - 20	72	33.0	38.1	4.6	5.05	15.0	1.5	6.4	R 3.5 P 1.5	5,6,7		
W 5/16 - 18	77	36.7	42.3	6.1	6.48	15.0	2.0	7.1	R 4.5 P 1.5	5,6,7		
W 3/8 - 16	89	41.3	47.6	7.3	7.88	20.0	2.0	8.0	R 5.0 P 1.5	6,7,8		
W 7/16 - 14	102	47.2	54.4	8.6	9.19	25.0	3.0	9.0	R 6.0 P 2.0	6,7,8		
W 1/2 - 12	102	55.0	63.5	10.5	10.45	25.0	3.0	10.5	R 7.5 P 2.0	7,8,9		
W 9/16 - 12	114	55.0	63.5	9.5	12.07	30.0	3.0	10.5	R 7.5 P 2.0	7,8,9		
W 5/8 - 11	127	60.0	69.3	12.8	13.46	30.0	3.5	11.5	R 9.0 P 2.0	8,9,10		
W 3/4 - 10	133	66.0	76.2	15.0	16.41	30.0	4.0	12.7	R 12.0 P 3.0	9,10,11		
W 7/8 - 9	146	73.4	84.7	17.0	19.30	30.0	4.5	14.0	R 13.0 P 3.0	9,10,11		
W 1 - 8	165	82.6	95.3	20.0	22.12	35.0	5.0	15.9	R 16.0 P 3.0	9,10,11		

※有●者備有庫存。
● means we have the item in stock.

※無庫存及特殊品，歡迎訂製。
No stock or special specifications are available on request.



詮豐精密工具股份有限公司 Chuan Hong precision tool MFG.CO.,LTD

導引螺絲柄螺帽絲攻 (SBD)M Nut Tap (Coupler Type)

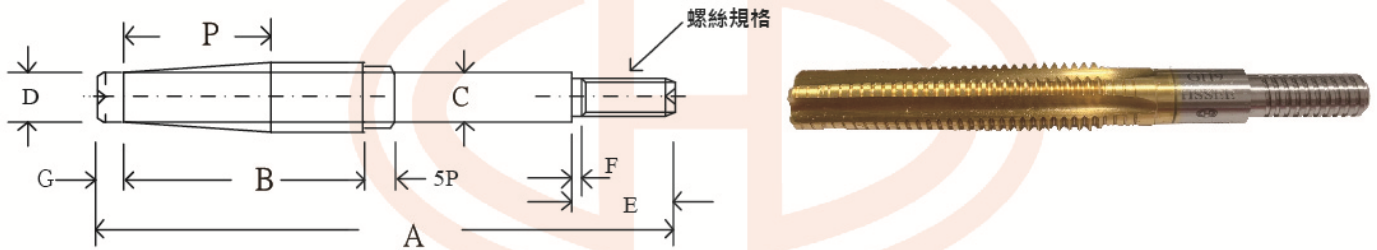

M 公制螺紋

單位: mm

規格 Specification	A 全長	B S45C	B SUS	CΦ 柄徑	D 先端徑	E 螺絲長	F	G	螺絲規格 Screw Size	GH 精度	S-45C直槽 TIN	SUS直槽 TACON
M 6 X 1.0	67	26.0	30.0	4.5	4.95	15.0	2.0	4.0	R 3.5 P 1.5	6,7,8		
M 8 X 1.0	77	26.0	30.0	6.4	6.95	15.0	2.5	4.0	R 4.5 P 1.5	6,7,8		
M 8 X 1.25	77	32.5	37.5	6.1	6.70	15.0	2.5	5.0	R 5.0 P 1.5	7,8,9		
M10 X 1.0	89	26.0	30.0	8.4	8.95	20.0	3.0	5.0	R 6.0 P 2.0	7,8,9		
M 10 X 1.25	89	32.5	37.5	8.1	8.70	20.0	3.0	5.0	R 6.0 P 2.0	7,8,9		
M 10 X 1.5	89	39.0	45.0	8.0	8.45	20.0	3.0	5.0	R 6.0 P 2.0	7,8,9		
M 12 X 1.0	102	26.0	30.0	10.4	10.95	25.0	3.5	6.0	R 8.0 P 2.0	7,8,9		
M 12 X 1.25	102	32.5	37.5	10.0	10.70	25.0	3.5	6.0	R 8.0 P 2.0	7,8,9		
M 12 X 1.5	102	39.0	45.0	9.8	10.42	25.0	3.5	6.0	R 7.5 P 2.0	7,8,9		
M 12 X 1.75	102	45.5	52.5	9.5	10.15	25.0	3.5	6.0	R 7.5 P 2.0	8,9,10		
M 14 X 1.0	114	26.0	30.0	12.4	12.95	25.0	4.0	7.0	R 9.0 P 2.0	7,8,9		
M 14 X 1.5	114	39.0	45.0	11.8	12.42	25.0	4.0	7.0	R 9.0 P 2.0	7,8,9		
M 14 X 2.0	114	52.0	60.0	11.2	11.90	25.0	4.0	7.0	R 9.0 P 2.0	8,9,10		
M 16 X 1.5	127	39.0	45.0	13.1	14.42	30.0	4.5	8.0	R10.0 P 3.0	8,9,10		
M 16 X 2.0	127	52.0	60.0	13.1	13.90	30.0	4.5	8.0	R10.0 P 3.0	8,9,10		
M 18 X 1.5	133	39.0	45.0	15.0	16.40	30.0	4.5	8.0	R12.0 P 3.0	8,9,10		
M 18 X 2.0	133	52.0	60.0	15.0	15.90	30.0	4.5	8.0	R12.0 P 3.0	8,9,10		
M 18 X 2.5	133	65.0	75.0	14.5	15.40	30.0	4.5	8.0	R12.0 P 3.0	8,9,10		
M 20 X 1.5	133	39.0	45.0	16.5	18.40	30.0	4.5	10.0	R13.0 P 3.0	8,9,10		
M 20 X 2.0	133	52.0	60.0	16.5	17.90	30.0	4.5	10.0	R13.0 P 3.0	8,9,10		
M 20 X 2.5	133	65.0	75.0	16.5	17.40	30.0	4.5	10.0	R13.0 P 3.0	8,9,10		
M 22 X 1.5	146	39.0	45.0	18.5	20.40	30.0	4.5	12.0	R14.0 P 3.0	8,9,10		
M 22 X 2.0	146	52.0	60.0	19.0	19.90	30.0	4.5	12.0	R16.0 P 3.0	8,9,10		
M 22 X 2.5	146	65.5	75.0	17.5	19.40	30.0	4.5	12.0	R14.0 P 3.0	8,9,10		
M 24 X 1.5	165	39.0	45.0	21.5	22.40	35.0	5.0	12.0	R16.0 P 3.0	8,9,10		
M 24 X 2.0	165	52.0	60.0	20.0	21.90	35.0	5.0	12.0	R16.0 P 3.0	8,9,10		
M 24 X 3.0	165	78.0	90.0	18.5	20.90	35.0	5.0	12.0	R18.0 P 3.0	9,10,11		
M 27 X 3.0	190	78.0	90.0	21.5	23.90	35.0	5.0	12.0	R18.0 P 3.0	9,10,11		
M 30 X 3.5	210	91.0	105.0	25.0	26.35	35.0	5.0	12.0	R18.0 P 3.0	9,10,11		

※有●者備有庫存。
● means we have the item in stock.

※無庫存及特殊品，歡迎訂製。
No stock or special specifications are available on request.



詮豐精密工具股份有限公司 Chuan Hong precision tool MFG.CO.,LTD

導引螺絲柄螺帽絲攻 (SBD) UNC.UNF Nut Tap (Coupler Type)

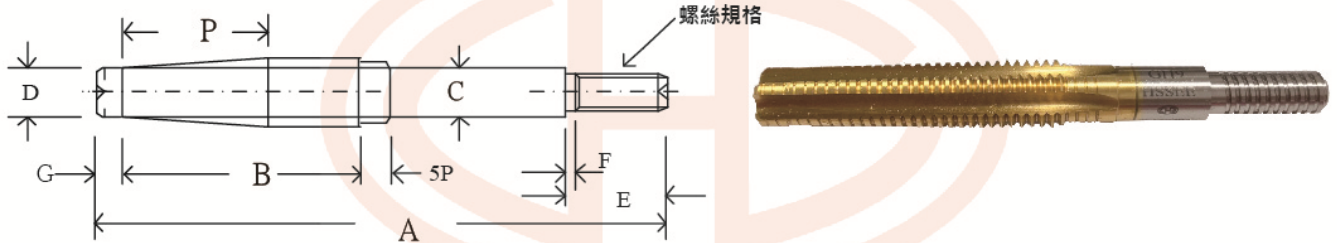

UNC 美制粗螺紋

單位：mm

規格 Specification	A 全長	B S45C	B SUS	CΦ 柄徑	D 先端徑	E 螺絲長	F	G	螺絲規格 Screw Size	GH 精度	S-45C直槽 TIN	SUS直槽 TACON
1/4 - 20UNC	72	33.0	38.1	4.5	5.05	15.0	1.5	4.0	R 3.5 P 1.5	6, 7, 8		
5/16 - 18UNC	77	36.7	42.3	6.0	6.48	15.0	2.0	5.0	R 4.5 P 1.5	6, 7, 8		
3/8 - 16UNC	89	41.3	47.6	7.3	7.88	20.0	2.0	6.0	R 5.0 P 1.5	6, 7, 8		
7/16 - 14UNC	102	47.2	54.4	8.6	9.19	20.0	3.0	6.0	R 6.0 P 1.5	7, 8, 9		
1/2 - 13UNC	102	50.8	58.6	10.0	10.65	25.0	3.0	8.0	R 7.5 P 2.0	8, 9, 10		
9/16 - 12UNC	114	55.0	63.5	11.0	12.07	25.0	3.0	8.0	R 7.5 P 2.0	8, 9, 10		
5/8 - 11UNC	127	60.0	69.3	12.8	13.47	25.0	3.5	10.0	R 9.5 P 3.0	8, 9, 10		
3/4 - 10UNC	133	66.0	76.2	15.0	16.41	30.0	4.0	10.0	R12.0 P 3.0	9, 10, 11		
7/8 - 9UNC	146	73.4	84.7	17.0	19.30	30.0	4.5	12.0	R13.0 P 3.0	9, 10, 11		
1 - 8UNC	165	82.6	95.3	20.0	22.12	35.0	5.0	12.0	R16.0 P 3.0	9, 10, 11		

UNF 美制細螺紋

單位：mm

規格 Specification	A 全長	B S45C	B SUS	CΦ 柄徑	D 先端徑	E 螺絲長	F	G	螺絲規格 Screw Size	GH 精度	S-45C直槽 TIN	SUS直槽 TACON
1/4 - 28UNF	72	23.6	27.2	5.0	5.38	15.0	1.5	4.0	R 3.5 P 1.5	5, 6, 7		
5/16 - 24UNF	77	27.5	31.7	6.3	6.83	15.0	2.0	5.0	R 4.5 P 1.5	5, 6, 7		
3/8 - 24UNF	89	27.5	31.7	8.0	8.40	20.0	2.0	6.0	R 5.5 P 1.5	6, 7, 8		
7/16 - 20UNF	102	33.0	38.1	9.3	9.74	25.0	3.0	6.0	R 7.5 P 2.0	7, 8, 9		
1/2 - 20UNF	102	33.0	38.1	10.9	11.33	25.0	3.0	8.0	R 8.0 P 2.0	7, 8, 9		
9/16 - 18UNF	114	36.7	42.3	11.4	12.78	30.0	3.0	8.0	R 9.0 P 2.0	8, 9, 10		
5/8 - 18UNF	127	36.7	42.3	13.1	14.36	30.0	3.5	10.0	R10.0 P 3.0	8, 9, 10		
3/4 - 16UNF	133	41.3	47.6	15.0	17.36	30.0	4.0	10.0	R12.0 P 3.0	8, 9, 10		
7/8 - 14UNF	146	47.2	54.4	18.5	20.31	30.0	4.5	12.0	R16.0 P 3.0	8, 9, 10		
1 - 12UNF	165	55.5	63.5	21.0	23.18	35.0	5.0	12.0	R16.0 P 3.0	8, 9, 10		

※有●者備有庫存。
● means we have the item in stock.

※無庫存及特殊品，歡迎訂製。
No stock or special specifications are available on request.



詮豐精密工具股份有限公司 Chuan Hong precision tool MFG.CO.,LTD

導引螺絲柄螺帽絲攻 (SBD)BSW Guide Nut Tap (Coupler Type)

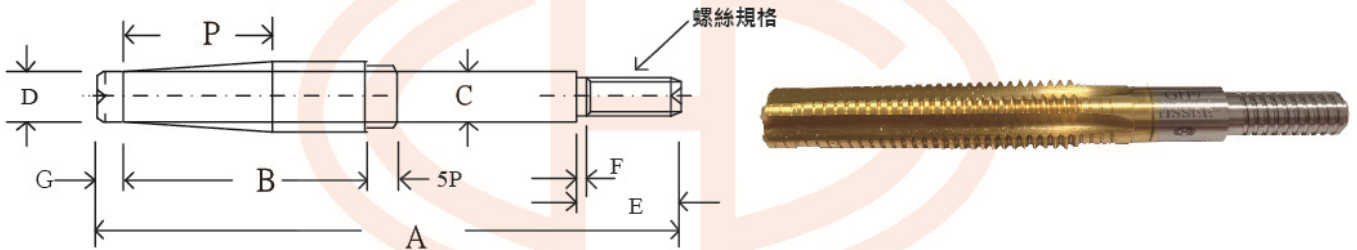

W 英制粗螺紋

單位: mm

規格 Specification	A 全長	B S45C	B SUS	CΦ 柄徑	D 先端徑	E 螺絲長	F	G	螺絲規格 Screw Size	GH 精度	S-45C直槽 TIN	SUS直槽 TACON
W 1/4 - 20	72	33.0	38.1	4.6	5.05	15.0	1.5	4.0	R 3.5 P 1.5	5,6,7		
W 5/16 - 18	77	36.7	42.3	6.1	6.48	15.0	2.0	5.0	R 4.5 P 1.5	5,6,7		
W 3/8 - 16	89	41.3	47.6	7.3	7.88	20.0	2.0	6.0	R 5.0 P 1.5	6,7,8		
W 7/16 - 14	102	47.2	54.4	8.6	9.19	25.0	3.0	6.0	R 6.0 P 2.0	6,7,8		
W 1/2 - 12	102	55.0	63.5	10.5	10.45	25.0	3.0	8.0	R 7.5 P 2.0	7,8,9		
W 9/16 - 12	114	55.0	63.5	9.5	12.07	30.0	3.0	8.0	R 7.5 P 2.0	7,8,9		
W 5/8 - 11	127	60.0	69.3	12.8	13.46	30.0	3.5	10.0	R 9.0 P 2.0	8,9,10		
W 3/4 - 10	133	66.0	76.2	15.0	16.41	30.0	4.0	10.0	R12.0 P 3.0	9,10,11		
W 7/8 - 9	146	73.4	84.7	17.0	19.30	30.0	4.5	12.0	R13.0 P 3.0	9,10,11		
W 1 - 8	165	82.6	95.3	20.0	22.12	35.0	5.0	12.0	R16.0 P 3.0	9,10,11		

※有●者備有庫存。
● means we have the item in stock.

※無庫存及特殊品, 歡迎訂製。
No stock or special specifications are available on request.

螺紋工具GH精度表 Thread Cutting Tools GH Limits

+0.127												GH10
+0.114												GH9
+0.101												GH8
+0.089												GH7
+0.077												GH6
+0.064												GH5
+0.051												GH4
+0.039												GH3
+0.026												GH2
+0.013												GH1
0												



詮豐精密工具股份有限公司 Chuan Hong precision tool MFG.CO.,LTD

螺帽絲攻接管 (SD)M

Coupler

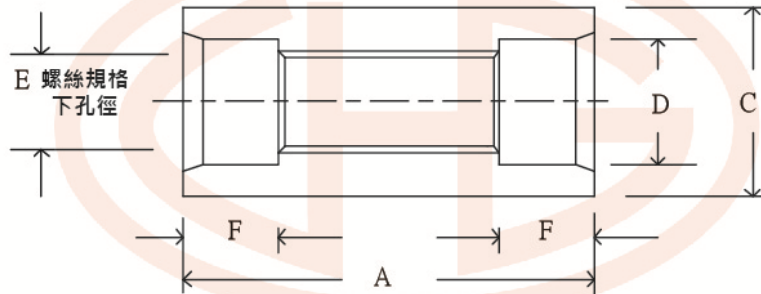

M 公制螺紋

單位：mm

規格 Specification	A 全長	C 柄徑	D 內徑	F	E	下孔徑 Hole Size	庫存 Stock
M 6 X 1.0	29.5	4.5	4.0	1.5	R 3.5 P 1.5	2.90	
M 8 X 1.0	29.5	6.4	5.2	2.0	R 4.5 P 1.5	3.90	
M 8 X 1.25	29.5	6.1	5.2	2.0	R 5.0 P 1.5	4.40	
M 10 X 1.0	39.5	8.4	6.2	2.5	R 6.0 P 2.0	5.04	
M 10 X 1.25	39.5	8.1	6.2	2.5	R 6.0 P 2.0	5.04	
M 10 X 1.5	39.5	8.0	6.2	2.5	R 6.0 P 2.0	5.04	
M 12 X 1.0	49.5	10.4	8.2	3.0	R 8.0 P 2.0	7.04	
M 12 X 1.25	49.5	10.0	8.2	3.0	R 8.0 P 2.0	7.04	
M 12 X 1.5	49.5	9.8	7.7	3.0	R 7.5 P 2.0	6.54	
M 12 X 1.75	49.5	9.5	7.7	3.0	R 7.5 P 2.0	6.54	
M 14 X 1.0	49.5	12.4	10.2	3.0	R 9.0 P 2.0	8.04	
M 14 X 1.5	49.5	11.2	9.2	3.0	R 9.0 P 2.0	8.04	
M 14 X 2.0	49.5	11.2	9.2	3.0	R 9.0 P 2.0	8.04	
M 16 X 1.5	59.5	13.1	10.2	3.5	R10.0 P 3.0	8.56	
M 16 X 2.0	59.5	13.1	10.2	3.5	R10.0 P 3.0	8.56	
M 18 X 1.5	59.5	15.0	12.2	4.0	R12.0 P 3.0	10.56	
M 18 X 2.0	59.5	15.0	12.2	4.0	R12.0 P 3.0	10.56	
M 18 X 2.5	59.5	14.5	12.2	4.0	R12.0 P 3.0	10.56	
M 20 X 1.5	59.5	16.5	14.2	4.0	R13.0 P 3.0	11.56	
M 20 X 2.0	59.5	16.5	14.2	4.0	R13.0 P 3.0	11.56	
M 20 X 2.5	59.5	16.5	14.2	4.0	R13.0 P 3.0	11.56	
M 22 X 1.5	59.5	18.5	16.2	4.0	R14.0 P 3.0	12.56	
M 22 X 2.0	59.5	19.0	16.2	4.0	R16.0 P 3.0	14.56	
M 22 X 2.5	59.5	17.5	15.2	4.0	R14.0 P 3.0	12.56	
M 24 X 1.5	69.5	21.5	18.2	5.0	R16.0 P 3.0	14.56	
M 24 X 2.0	69.5	20.0	17.2	5.0	R16.0 P 3.0	14.56	
M 24 X 3.0	69.5	18.5	16.5	5.0	R16.0 P 3.0	14.56	
M 27 X 3.0	69.5	21.5	18.5	6.0	R18.0 P 3.0	16.56	
M 30 X 3.5	69.5	25.0	18.5	6.0	R18.0 P 3.0	16.56	

※有●者備有庫存。
● means we have the item in stock.

※無庫存及特殊品，歡迎訂製。
No stock or special specifications are available on request.



註豐精密工具股份有限公司 Chuan Hong precision tool MFG.CO.,LTD

螺帽絲攻接管 (SD)UNC.UNF Coupler

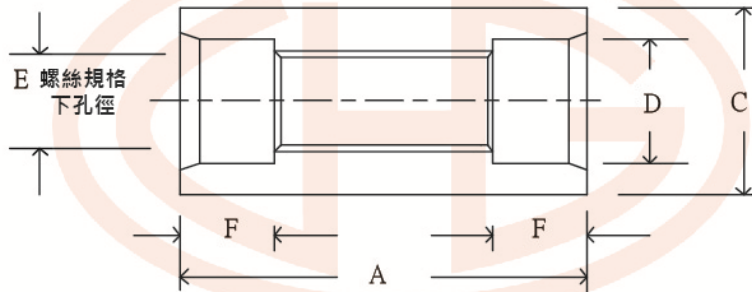

UNC 美制粗螺紋

單位：mm

規格 Specification	A 全長	C 柄徑	D 內徑	F	E	下孔徑 Hole Size	庫存 Stock
1/4 - 20UNC	29.5	4.6	3.53	1.5	R 3.5 P 1.5	2.90	
5/16 - 18UNC	29.5	6.1	4.53	2.0	R 4.5 P 1.5	3.90	
3/8 - 16UNC	39.5	7.3	5.03	2.0	R 5.0 P 1.5	4.40	
7/16 - 14UNC	39.5	8.6	6.03	3.0	R 6.0 P 2.0	5.04	
1/2 - 13UNC	49.5	10.0	7.53	3.0	R 7.5 P 2.0	6.54	
9/16 - 12UNC	49.5	10.5	7.53	3.0	R 7.5 P 2.0	6.54	
5/8 - 11UNC	49.5	12.8	9.53	3.5	R 9.5 P 3.0	8.06	
3/4 - 10UNC	59.5	15.0	12.04	4.0	R12.0 P 3.0	10.56	
7/8 - 9UNC	59.5	17.0	13.04	4.5	R13.0 P 3.0	11.56	
1 - 8UNC	69.5	20.0	16.05	5.0	R16.0 P 3.0	14.56	

UNF 美制細螺紋

單位：mm

規格 Specification	A 全長	C 柄徑	D 內徑	F	E	下孔徑 Hole Size	庫存 Stock
1/4 - 28UNF	29.5	5.0	3.53	1.5	R 3.5 P 1.5	2.90	
5/16 - 24UNF	29.5	6.3	4.53	2.0	R 4.5 P 1.5	3.90	
3/8 - 24UNF	39.5	8.0	5.03	2.0	R 5.0 P 1.5	4.40	
7/16 - 20UNF	49.5	9.3	7.53	3.0	R 7.5 P 2.0	6.54	
1/2 - 20UNF	49.5	10.9	8.03	3.0	R 8.0 P 2.0	7.04	
9/16 - 18UNF	59.5	11.4	9.03	3.0	R 9.0 P 2.0	8.04	
5/8 - 18UNF	59.5	13.1	10.04	3.5	R10.0 P 3.0	8.56	
3/4 - 16UNF	59.5	15.0	12.04	4.0	R12.0 P 3.0	10.56	
7/8 - 14UNF	59.5	18.0	13.04	4.5	R16.0 P3.0	11.56	
1 - 12UNF	69.5	21.0	16.05	5.0	R16.0 P3.0	14.56	

※有●者備有庫存。
● means we have the item in stock.

※無庫存及特殊品，歡迎訂製。
No stock or special specifications are available on request.



詮豐精密工具股份有限公司 Chuan Hong precision tool MFG.CO.,LTD

螺帽絲攻接管 (SD)BSW Coupler

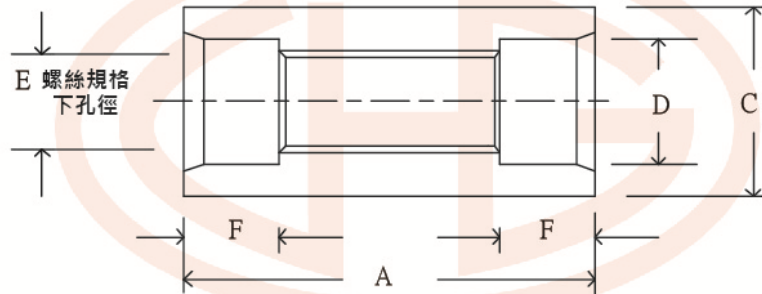

W 英制粗螺紋

單位: mm

規格 Specification	A 全長	C 柄徑	D 內徑	F	E	下孔徑 Hole Size	庫存 Stock
W 1/4 - 20	29.5	4.6	3.53	1.5	R 3.5 P 1.5	2.90	
W 5/16 - 18	29.5	6.1	4.53	2.0	R 4.5 P 1.5	3.90	
W 3/8 - 16	39.5	7.3	5.03	2.0	R 5.0 P 1.5	4.40	
W 7/16 - 14	49.5	8.6	6.03	3.0	R 6.0 P 2.0	5.04	
W 1/2 - 12	49.5	9.5	7.53	3.0	R 7.5 P 2.0	6.54	
W 9/16 - 12	59.5	10.5	7.53	3.0	R 7.5 P 2.0	6.54	
W 5/8 - 11	59.5	12.8	9.03	3.5	R 9.0 P 2.0	8.04	
W 3/4 - 10	59.5	15.0	12.04	4.0	R12.0 P 3.0	10.56	
W 7/8 - 9	59.5	17.0	13.04	4.5	R13.0 P 3.0	11.56	
W 1 - 8	69.5	20.0	16.05	5.0	R16.0 P 3.0	14.56	

※有●者備有庫存。
● means we have the item in stock.

※無庫存及特殊品，歡迎訂製。
No stock or special specifications are available on request.



詮豐精密工具股份有限公司 Chuan Hong precision tool MFG.CO.,LTD

螺帽絲攻彎柄 (SN)M Bent Shank

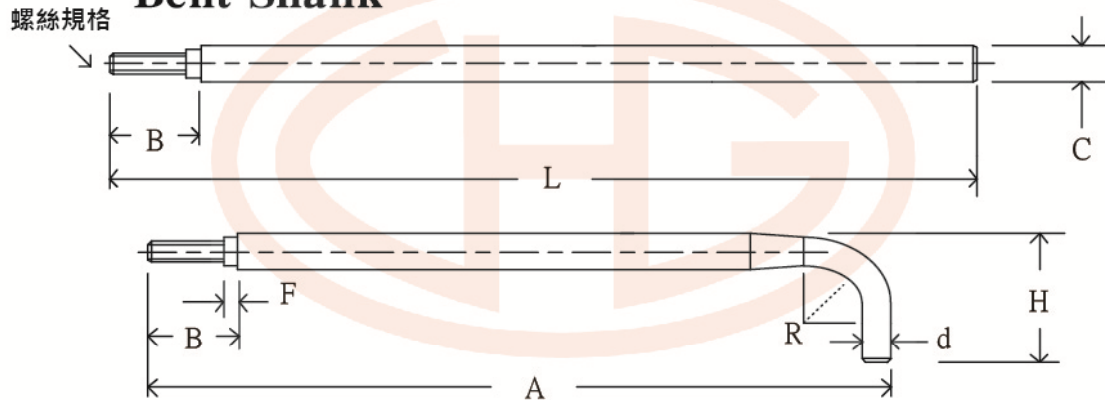

M 公制螺紋

A, R, H, F 僅供參考
For reference only

規格 Specification	A	B	C	F	螺絲規格 Screw Size	L	d	R	H	F	庫存 Stock
M 6 X 1.0	245	15.0	4.50	1.5	R 3.5 P 1.5	330	4.0	30	40	80	
M 8 X 1.0	252	15.0	6.40	2.0	R 4.5 P 1.5	330	5.8	30	40	80	
M 8 X 1.25	252	15.0	6.10	2.0	R 5.0 P 1.5	330	5.5	30	40	80	
M 10 X 1.0	254	20.0	8.40	2.5	R 6.0 P 2.0	495	7.6	30	40	80	
M 10 X 1.25	254	20.0	8.10	2.5	R 6.0 P 2.0	495	7.4	30	40	80	
M 10 X 1.5	254	20.0	8.00	2.5	R 6.0 P 2.0	495	7.2	30	40	80	
M 12 X 1.0	387	25.0	10.40	3.0	R 8.0 P 2.0	495	9.6	45	52	100	
M 12 X 1.25	387	25.0	10.00	3.0	R 8.0 P 2.0	495	9.2	45	52	100	
M 12 X 1.5	387	25.0	9.80	3.0	R 7.5 P 2.0	495	9.0	45	52	100	
M 12 X 1.75	387	25.0	9.50	3.0	R 7.5 P 2.0	495	8.8	45	52	100	
M 14 X 1.0	387	25.0	12.40	3.0	R 9.0 P 2.0	495	11.5	45	52	100	
M 14 X 1.5	387	25.0	11.80	3.0	R 9.0 P 2.0	495	10.3	45	52	100	
M 14 X 2.0	387	25.0	11.20	3.0	R 9.0 P 2.0	495	10.3	45	52	100	
M 16 X 1.5	497	30.0	13.10	3.5	R10.0 P 3.0	630	12.1	65	80	140	
M 16 X 2.0	497	30.0	13.10	3.5	R10.0 P 3.0	630	12.1	65	80	140	
M 18 X 1.5	498	30.0	15.00	4.0	R12.0 P 3.0	630	14.0	65	80	140	
M 18 X 2.0	498	30.0	15.00	4.0	R12.0 P 3.0	630	14.0	65	80	140	
M 18 X 2.5	498	30.0	14.50	4.0	R12.0 P 3.0	630	13.5	65	80	140	
M 20 X 1.5	538	30.0	16.50	4.0	R13.0 P 3.0	630	15.2	65	80	140	
M 20 X 2.0	538	30.0	16.50	4.0	R13.0 P 3.0	630	15.2	65	80	140	
M 20 X 2.5	538	30.0	16.00	4.0	R13.0 P 3.0	630	13.8	65	80	140	
M 22 X 1.5	540	30.0	18.50	4.0	R14.0 P 3.0	630	17.0	65	80	140	
M 22 X 2.0	540	30.0	19.00	4.0	R16.0 P 3.0	630	17.5	65	80	140	
M 22 X 2.5	540	30.0	17.50	4.0	R14.0 P 3.0	630	16.0	65	80	140	
M 24 X 1.5	545	35.0	21.50	5.0	R16.0 P 3.0	630	19.0	65	80	140	
M 24 X 2.0	545	35.0	20.00	5.0	R16.0 P 3.0	630	18.5	65	80	140	
M 24 X 3.0	545	35.0	18.50	5.0	R16.0 P 3.0	630	17.0	65	80	140	
M 27 X 3.0	545	35.0	21.50	5.0	R18.0 P 3.0	630	20.0	65	80	140	
M 30 X 3.5	545	35.0	25.00	5.0	R18.0 P 3.0	630	22.5	65	80	140	

※有●者備有庫存。
● means we have the item in stock.

※無庫存及特殊品，歡迎訂製。
No stock or special specifications are available on request.



詮豐精密工具股份有限公司 Chuan Hong precision tool MFG.CO.,LTD

螺帽絲攻彎柄 (SN)UNC.UNF Bent Shank

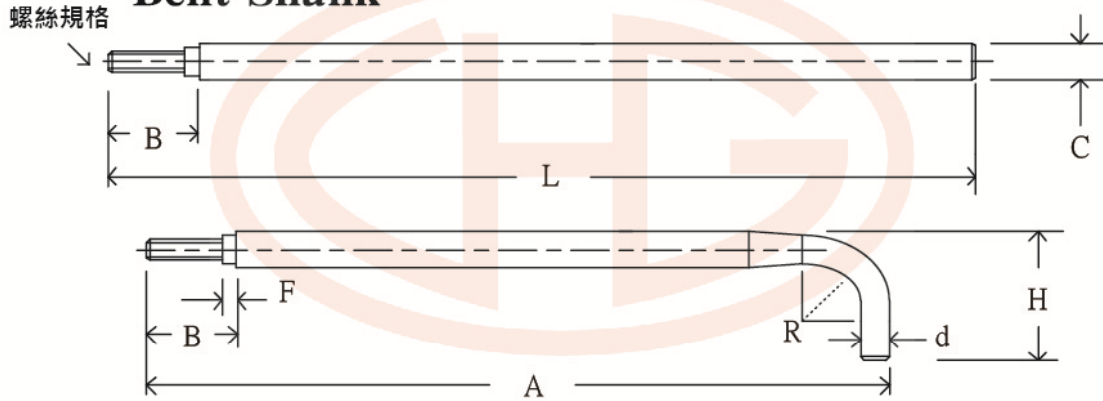

UNC 美制粗螺紋

A, R, H, F 僅供參考
For reference only

規格 Specification	A	B	C	F	螺絲規格 Screw Size	L	d	R	H	F	庫存 Stock
1/4 - 20UNC	245	15.0	4.60	1.5	R 3.5 P 1.5	330	4.00	30	40	80	
5/16 - 18UNC	250	15.0	6.10	2.0	R 4.5 P 1.5	330	5.60	30	40	80	
3/8 - 16UNC	254	20.0	7.30	2.0	R 5.0 P 1.5	330	6.50	30	40	80	
7/16 - 14UNC	257	20.0	8.60	3.0	R 6.0 P 2.0	495	7.90	30	40	80	
1/2 - 13UNC	387	25.0	9.50	3.0	R 7.5 P 2.0	495	9.20	45	52	100	
9/16 - 12UNC	389	25.0	10.50	3.0	R 7.5 P 2.0	495	9.80	45	52	100	
5/8 - 11UNC	497	25.0	12.80	3.5	R 9.5 P 3.0	660	12.00	65	80	140	
3/4 - 10UNC	493	30.0	15.00	4.0	R12.0 P 3.0	660	14.00	65	80	140	
7/8 - 9UNC	496	30.0	17.00	4.5	R13.0 P 3.0	660	16.00	65	80	140	
1 - 8UNC	505	35.0	20.00	5.0	R16.0 P 3.0	660	18.80	65	80	140	

UNF 美制細螺紋

A, R, H, F 僅供參考
For reference only

規格 Specification	A	B	C	F	螺絲規格 Screw Size	L	d	R	H	F	庫存 Stock
1/4 - 28UNF	245	15.0	5.00	1.5	R 3.5 P 1.5	330	4.00	30	40	80	
5/16 - 24UNF	250	15.0	6.30	2.0	R 4.5 P 1.5	330	5.80	30	40	80	
3/8 - 24UNF	254	20.0	8.00	2.0	R 5.0 P 1.5	330	7.30	30	40	80	
7/16 - 20UNF	257	25.0	9.30	3.0	R 7.5 P 2.0	495	8.50	30	40	80	
1/2 - 20UNF	387	25.0	10.90	3.0	R 8.0 P 2.0	495	10.10	45	52	100	
9/16 - 18UNF	389	30.0	11.40	3.0	R 9.0 P 2.0	495	10.50	45	52	100	
5/8 - 18UNF	497	30.0	13.10	3.5	R10.0 P 3.0	660	12.20	65	80	140	
3/4 - 16UNF	493	30.0	15.00	4.0	R12.0 P 3.0	660	14.00	65	80	140	
7/8 - 14UNF	496	30.0	18.00	4.5	R14.0 P 3.0	660	17.00	65	80	140	
1 - 12UNF	505	35.0	21.00	5.0	R16.0 P 3.0	660	20.00	65	80	140	

※有●者備有庫存。
● means we have the item in stock.

※無庫存及特殊品，歡迎訂製。
No stock or special specifications are available on request.



詮豐精密工具股份有限公司 Chuan Hong precision tool MFG.CO.,LTD

螺帽絲攻彎柄 (SN)W Bent Shank

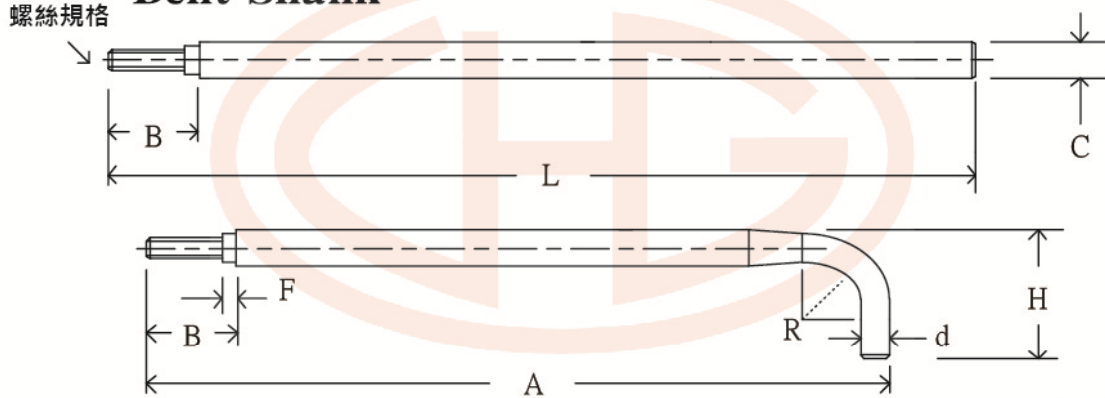

W 英制粗螺紋

A, R, H, F 僅供參考
For reference only

規格 Specification	A	B	C	F	螺絲規格 Screw Size	L	d	R	H	F	庫存 Stock
W 1/4 - 20	245	15.0	4.60	1.5	R 3.5 P 1.5	330	4.00	30	40	80	
W 5/16 - 18	250	15.0	6.10	2.0	R 4.5 P 1.5	330	5.60	30	40	80	
W 3/8 - 16	254	20.0	7.30	2.0	R 5.0 P 1.5	330	6.50	30	40	80	
W 7/16 - 14	257	25.0	8.60	3.0	R 6.0 P 2.0	495	7.90	30	40	80	
W 1/2 - 12	387	25.0	9.50	3.0	R 7.5 P 2.0	495	8.70	45	52	100	
W 9/16 - 12	389	30.0	10.50	3.0	R 7.5 P 2.0	495	9.80	45	52	100	
W 5/8 - 11	497	30.0	12.80	3.5	R 9.0 P 2.0	660	12.00	65	80	140	
W 3/4 - 10	493	30.0	15.00	4.0	R12.0 P 3.0	660	14.00	65	80	140	
W 7/8 - 9	496	30.0	17.00	4.5	R13.0 P 3.0	660	16.00	65	80	140	
W 1 - 8	505	35.0	20.00	5.0	R16.0 P 3.0	660	18.80	65	80	140	

※有●者備有庫存。
● means we have the item in stock.

※無庫存及特殊品，歡迎訂製。
No stock or special specifications are available on request.



詮豐精密工具股份有限公司 Chuan Hong precision tool MFG.CO.,LTD

螺旋絲攻.先端絲攻 (SFT.POT)M Spiral Flute Taps & Spiral Point Taps



M 公制螺紋

單位: mm

規格 Specification	A 全長	B 牙長	CΦ 柄徑	E	F	GH 精度	type 型式	螺旋絲攻 SFT	先端絲攻 POT
M 3 X 0.5	46	11.0	4.0	6	3.2	2	1		
M3.5 X 0.6	48	13.0	4.0	6	3.2	2	1		
M 4 X 0.7	52	13.0	5.0	7	4.0	2	1		
M 5 X 0.8	60	16.0	5.5	7	4.5	2	1		
M 6 X 1.0	62	19.0	6.0	7	4.5	3	2		
M 8 X 1.0	70	22.0	6.2	8	5.0	3	2		
M 8 X 1.25	70	22.0	6.2	8	5.0	3	2		
M10 X 1.25	75	24.0	7.0	8	5.5	3	2		
M10 X 1.5	75	24.0	7.0	8	5.5	3	2		
M12 X 1.25	82	29.0	8.5	9	6.5	4	2		
M12 X 1.5	82	29.0	8.5	9	6.5	4	2		
M12 X 1.75	82	29.0	8.5	9	6.5	4	2		
M14 X 1.5	88	30.0	10.5	11	8.0	4	2		
M14 X 2.0	88	30.0	10.5	11	8.0	4	2		
M16 X 1.5	95	32.0	12.5	13	10.0	5	2		
M16 X 2.0	95	32.0	12.5	13	10.0	5	2		
M18 X 1.5	100	37.0	14.0	14	11.0	5	2		
M18 X 2.0	100	37.0	14.0	14	11.0	5	2		
M18 X 2.5	100	37.0	14.0	14	11.0	5	2		
M20 X 1.5	105	37.0	15.0	15	12.0	5	2		
M20 X 2.5	105	37.0	15.0	15	12.0	5	2		
M22 X 2.5	115	38.0	17.0	16	13.0	5	2		
M24 X 1.5	120	45.0	19.0	18	15.0	5	2		
M24 X 3.0	120	45.0	19.0	18	15.0	5	2		

※有●者備有庫存。
● means we have the item in stock.

※無庫存及特殊品，歡迎訂製。
No stock or special specifications are available on request.



詮豐精密工具股份有限公司 Chuan Hong precision tool MFG.CO.,LTD

螺旋絲攻.先端絲攻 (SFT.POT)UNC Spiral Flute Taps & Spiral Point Taps



UNC 美制粗螺紋

單位: mm

規格 Specification	A 全長	B 牙長	CΦ 柄徑	E	F	GH 精度	type 型式	螺旋絲攻 SFT	先端絲攻 POT
NO.4-40UNC	46	11.0	4.0	6	3.2	2	1		
NO:6-32UNC	48	13.0	4.0	6	3.2	2	1		
NO:8-32UNC	52	13.0	5.0	7	4.0	2	1		
NO:10-24UNC	60	16.0	5.5	7	4.5	2	1		
NO:12-24UNC	60	16.0	5.5	7	4.5	3	2		
1/4 - 20UNC	62	19.0	6.0	7	4.5	3	2		
5/16 - 18UNC	70	22.0	6.2	8	5.0	3	2		
3/8 - 16UNC	75	24.0	7.0	8	5.5	3	2		
7/16 - 14UNC	80	25.0	8.0	8	5.5	3	2		
1/2 - 13UNC	85	29.0	9.0	9	6.5	4	2		
9/16 - 12UNC	90	30.0	10.5	11	8.0	4	2		
5/8 - 11UNC	95	32.0	12.0	13	10.0	5	2		
3/4 - 10UNC	105	37.0	14.0	14	11.0	5	2		
7/8 - 9UNC	115	38.0	17.0	16	13.0	5	2		
1 - 8UNC	125	45.0	20.0	18	15.0	5	2		

※有●者備有庫存。
● means we have the item in stock.

※無庫存及特殊品，歡迎訂製。
No stock or special specifications are available on request.



詮豐精密工具股份有限公司 Chuan Hong precision tool MFG.CO.,LTD

螺旋絲攻.先端絲攻 (SFT.POT)UNF Spiral Flute Taps & Spiral Point Taps



UNF 美制細螺紋

單位: mm

規格 Specification	A 全長	B 牙長	CΦ 柄徑	E	F	GH 精度	type 型式	螺旋絲攻 SFT	先端絲攻 POT
NO:5-44UNF	46	11.0	4.0	6	3.2	2	1		
NO:6-40UNF	48	13.0	4.0	6	3.2	2	1		
NO:8-36UNF	52	13.0	5.0	7	4.0	2	1		
NO:10-32UNF	60	16.0	5.5	7	4.5	2	1		
NO:12-28UNF	60	16.0	5.5	7	4.5	3	2		
1/4"28UNC	62	19.0	6.0	7	4.5	3	2		
5/16"-24UNF	70	22.0	6.2	8	5.0	3	2		
3/8"20UNF	75	24.0	7.0	8	5.5	3	2		
7/16"-20UNF	80	25.0	8.0	8	5.5	3	2		
1/2"20UNF	85	29.0	9.0	9	6.5	4	2		
9/16"-18UNF	90	30.0	10.5	11	8.0	4	2		
5/8"-18UNF	95	32.0	12.0	13	10.0	5	2		
3/4"-16UNF	105	37.0	14.0	14	11.0	5	2		
7/8"-14UNF	115	38.0	17.0	16	13.0	5	2		
1"-12UNF	125	45.0	20.0	18	15.0	5	2		

※有●者備有庫存。
● means we have the item in stock.

※無庫存及特殊品，歡迎訂製。
No stock or special specifications are available on request.



詮豐精密工具股份有限公司 Chuan Hong precision tool MFG.CO.,LTD

無削絲攻 (FT)M Forming Taps

B=2牙
P=4牙

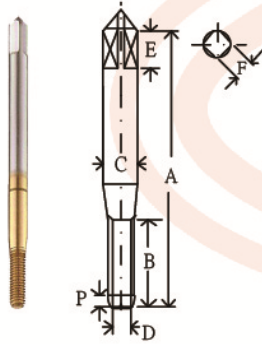

Type=1

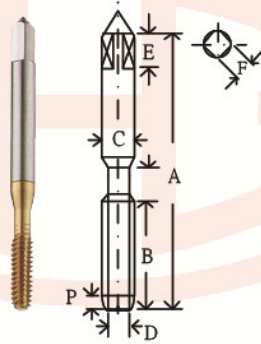

Type=2

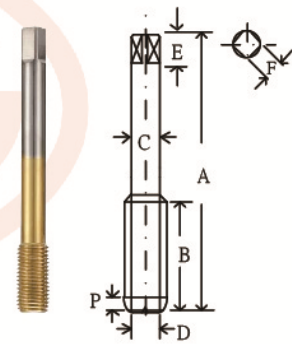

Type=3

M 公制螺紋

單位: mm

規格 Specification	A 全長	B 牙長	CΦ 柄徑	E	F	GH 精度	type 型式	食付 B	食付 P
M 1.7 X 0.35	36	8	3.0	5	2.5	3,4	1		
M 2 X 0.4	40	8	3.0	5	2.5	3,4,5	1		
M2.3 X 0.4	42	8	3.0	5	2.5	4,6	1		
M2.5 X 0.45	44	10	3.0	5	2.5	4,6	1		
M2.6 X 0.45	44	10	3.0	5	2.5	4,5,6	1		
M 3 X 0.5	46	10	4.0	6	3.2	4,5,6	2		
M3.5 X 0.6	48	10	4.0	6	3.2	6	2		
M 4 X 0.7	52	10	5.0	7	4.0	5,6,7	2		
M 5 X 0.8	60	11	5.5	7	4.0	5,6,7	2		
M 6 X 1.0	62	12	6.0	7	4.0	6,7,8	2		
M 8 X 1.0	70	18	6.2	8	5.0	6,7,8	3		
M 8 X 1.25	70	18	6.2	8	5.0	6,7,8	3		
M10 X 1.25	75	18	7.0	8	5.5	6,7,8	3		
M10 X 1.5	75	18	7.0	8	5.5	6,7,8	3		
M12 X 1.25	82	23	8.5	9	6.5	6,7,8	3		
M12 X 1.5	82	23	8.5	9	6.5	6,7,8	3		
M12 X 1.75	82	23	8.5	9	6.5	7,8,9	3		
M14 X 1.5	88	25	10.5	11	8.0	9	3		
M14 X 2.0	88	25	10.5	11	8.0	10	3		
M16 X 1.5	95	27	12.5	13	10.0	9	3		
M16 X 2.0	95	27	12.5	13	10.0	10	3		

※有●者備有庫存。
● means we have the item in stock.

※無庫存及特殊品，歡迎訂製。
No stock or special specifications are available on request.



詮豐精密工具股份有限公司 Chuan Hong precision tool MFG.CO.,LTD

無削絲攻 (FT)UNC Forming Taps

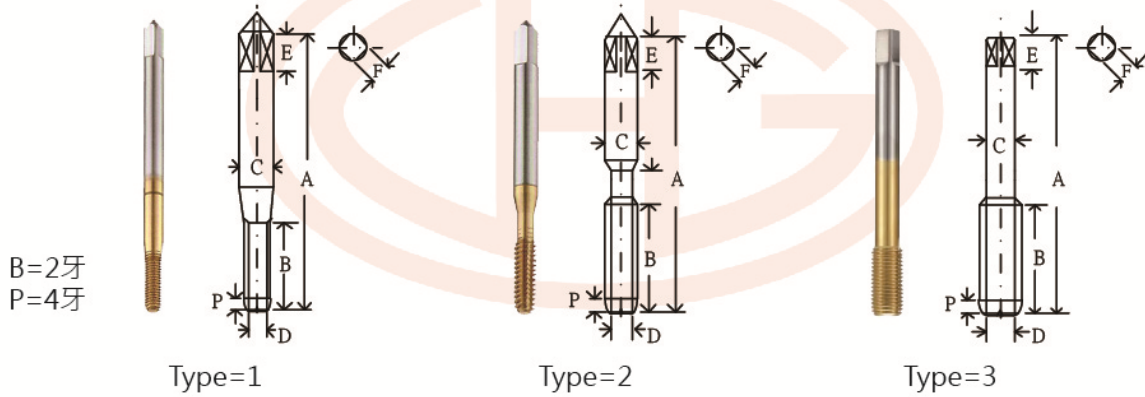

UNC 美制粗螺紋

單位: mm

規格 Specification	A 全長	B 牙長	CΦ 柄徑	E	F	GH 精度	type 型式	食付 B	食付 P
NO:2-56UNC	42	8	3.0	5	2.5	4	1		
NO:4-40UNC	31	9	3.0	5	2.5	4	1		
NO:6-32UNC	34	10	4.0	5	2.5	5,6	2		
NO:8-32UNC	36	10	5.0	5	2.5	5,6	2		
NO:10-24UNC	36	11	5.5	5	2.5	5,6,7	2		
NO:12-24UNC	40	11	5.5	5	2.5	5,6,7	2		
1/4 - 20UNC	42	14	6.0	5	2.5	6,7,8	2		
5/16 - 18UNC	44	18	6.1	5	2.5	7,8,9	2		
3/8 - 16UNC	44	21	7.0	5	2.5	7,8,9	3		
1/2 - 13UNC	46	25	9.0	6	3.2	8,9	3		

UNF 美制細螺紋

單位: mm

規格 Specification	A 全長	B 牙長	CΦ 柄徑	E	F	GH 精度	type 型式	食付 B	食付 P
NO:10-32UNF	60	11	5.5	5	2.5	5,6,7	2		
1/4 - 28UNF	62	14	6.0	5	2.5	5,6,7	2		
5/16 - 24UNF	70	18	6.1	5	2.5	7,8,9	3		
3/8 - 24UNF	75	21	7.0	5	2.5	7,8,9	3		
1/2 - 20UNF	85	25	9.0	5	2.5	8,9	3		

※有●者備有庫存。
● means we have the item in stock.

※無庫存及特殊品，歡迎訂製。
No stock or special specifications are available on request.



詮豐精密工具股份有限公司 Chuan Hong precision tool MFG.CO.,LTD

行星式小滾輪

Thread Small Rolling Dies

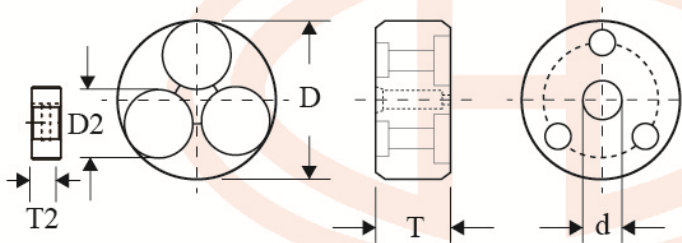

單位：mm

D 本體外徑	規格 Specification	T 本體厚度	dΦ 本體內徑	D2 滾輪外徑	T2 滾輪厚度	個數 pcs/set	備註 Remark
25	M3 x 0.5	4.0	10	10.0	5.0	3	
30	M4 x 0.7	5.0	12	10.0	5.0	3	
	M5 x 0.8	6.0	12	14.0	6.0	3	
	M6 x 1.0	7.0	12	14.0	6.0	3	
40	M8 x 0.75	9.5	15	16.0	8.0	3	
	M8 x 1.0	9.5	15	16.0	8.0	3	
	M8 x 1.25	9.5	15	16.0	8.0	3	
50	M10 x 0.75	11.5	18	20.0	10.0	3	
	M10 x 1.0	11.5	18	20.0	10.0	3	
	M10 x 1.25	11.5	18	20.0	10.0	3	
40	7.6SW12-2L	9.0	15	16.0	12.0	3	
	8.1SW12-2L	9.5	15	16.0	12.0	3	
	9.0SW10-2L	10.5	15	16.0	12.0	3	
50	10SW10-2L	12.0	18	20.0	15.0	3	
	11.5SW10-2L	13.0	18	20.0	15.0	3	
	13.8SW8-2L	15.0	18	20.0	15.0	3	
65	15.8SW8-2L	17.0	22	28.0	15.0	3	
40	7.6TW12-2L	9.0	15	16.0	12.0	3	
	8.5TW12-2L	10.0	15	16.0	12.0	3	
	9.5TW10-2L	11.0	15	20.0	12.0	3	
50	11.2TW10-2L	13.0	18	20.0	15.0	3	
	13.5TW8-2L	15.0	18	20.0	15.0	3	
	14.2TW8-2L	16.0	18	20.0	15.0	3	
65	15.8TW8-2L	17.0	22	28.0	15.0	3	
	17.5TW6-2L	19.0	22	28.0	15.0	3	

※有●者備有庫存。
● means we have the item in stock.

※無庫存及特殊品，歡迎訂製。
No stock or special specifications are available on request.



詮豐精密工具股份有限公司 Chuan Hong precision tool MFG.CO.,LTD

螺絲滾輪 Thread Rolling Dies

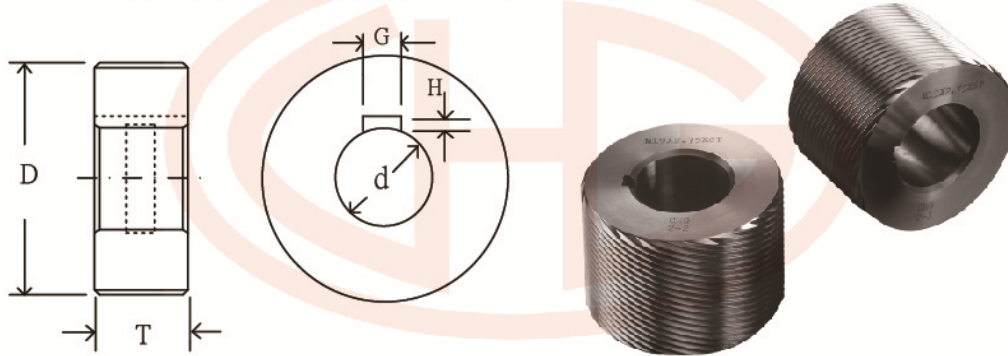

單位：mm

產品編號 Specification	型式 Type	D 外徑	dΦ 內徑	G 鍵槽	H 鍵槽	T 厚度	個數 pcs/set	備註 Remark
TRS2-020	CHTPG	20	12.0			40	2	
TRS3-050	30A	50	20.0	6.4	3.2	25 40	3 3	
TRS3-065	30A	65	25.4	6.4	3.2	25 40	3 3	
TRS3-080	30A	80	25.4	6.4	3.2	25 40	3 3	
TRT2-100	3T	100	50.5	8.0	4.2	30 50	2 2	
TRT2-120	IC-310	120	50.5	8.0	4.5	30 50	2 2	(可滾通)
TRS3-120	60A	120	40.0	8.0	4.2	25 50	2 2	
TRS2-120	IC-20D	120	40.0	8.0	4.2	25 50	2 2	
TRS2-150	IC-30D FDY-30	150	54.0	10.0	5.2	60 70	2 2	
TRT2-170	IC-515	170	54.0	10.0	5.2	35 70	2 2	
TRT2-180	IC-530 IC-530S FDY-30	180	54.0	10.0	5.2	70 100 150	2 2 2	
TRT2-200	100 150 200	200	70.0	14.0	7.5	100 150 200	2 2 2	

※有●者備有庫存。
● means we have the item in stock.

※無庫存及特殊品，歡迎訂製。
No stock or special specifications are available on request.



詮豐精密工具股份有限公司 Chuan Hong precision tool MFG.CO.,LTD

螺絲攻溝槽研磨機 Tap Lapping Machine

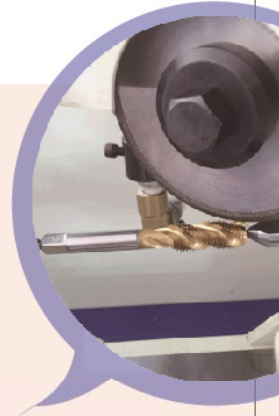

功能 FUNTION

1. 直槽絲攻之溝槽修磨
Grinding Flutes of Straight Taps
2. 螺旋絲攻之溝槽修磨
Grinding Flutes of Spiral Flute Tap
3. 先端絲攻之溝槽修磨
Grinding Flutes of Spiral Point Taps
4. 螺帽絲攻之溝槽修磨
Grinding Flutes of Nut Taps.
5. 絞刀之溝槽修磨
Grinding Flutes of Reamer.

工作台左右行程	180mm	Table Longitudinal Travel
工作台前後行程	100mm	Table Cross Trave
砂輪頭上下行程	150mm	Grinding Head Vertical Travel
升降柱旋轉角度	360	Column Swivel
砂輪頭旋轉角度	360	Grinding Head Swivel
砂輪尺寸	100 x 3~22mm	Grinding Wheel Size
砂輪驅動馬力	1/3HP,220V/380V	Motor
砂輪轉速	3,400RPM	Wheel Speed

螺絲攻溝槽磨修
位置圖

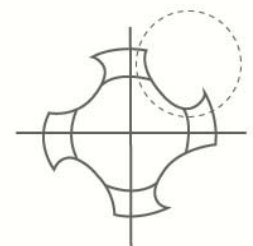

螺帽絲攻 柄徑(可用於長彎柄) 3 ~22 mm
Shank Diameter of Nut Taps(Long bent handle is available) 3 ~22 mm
機械絲攻 柄徑 3~100 mm ; 長度 180 mm
Shank Diameter of Mechanical Tap 3~100 mm ; Overall Length less 180 mm

螺旋絲攻
SFT



螺帽絲攻
NUT TAP

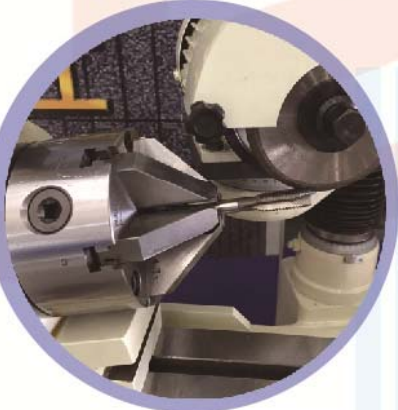

先端絲攻
POT

切削角測定儀 Cutting Angle Measuring Instrument

※配合螺絲攻溝槽研磨機

柄徑 3 ~36 mm
Shank Diameter 3 ~36 mm
長度 240 mm
Overall Length less 240 mm

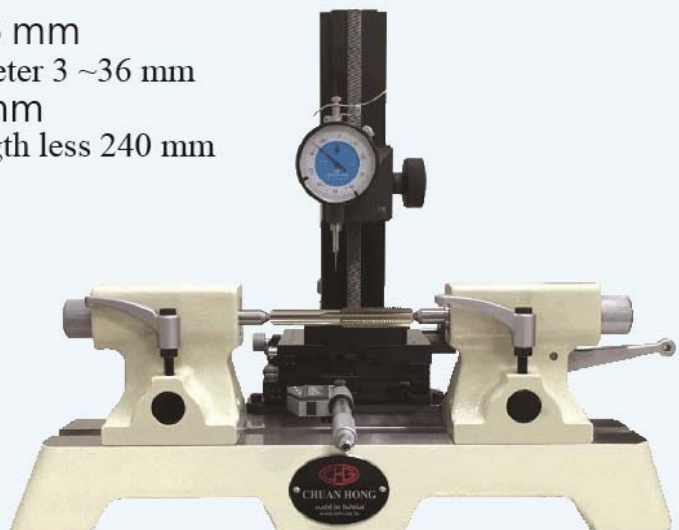



註豐精密工具股份有限公司 Chuan Hong precision tool MFG.CO.,LTD

螺帽檢測儀 OD Concentricity Measuring Instrument

螺帽檢測儀可量測圓棒、沖棒平行度

配合螺帽同心規可量測螺帽偏心率

Check parallelism of pin gauge or punch mould.

Assess nut deviation to used together with

concentricity thread plug gauge.



※另有螺絲檢測儀

1. 量測螺帽的傾斜度
Measurement of the inclination of the nut.
2. 判斷螺帽的有效徑
Analyzing the effective diameter of the nut.
3. 判斷螺帽熱處理的變形量
To determine the amount of deformation of the nut heat treatment.
4. 判斷螺帽鍍膜的膜厚
To determine coating thickness of nut.
5. 使用螺絲攻精度選別之參考
Use the screw attack precision sorting of reference.
6. 量測螺絲的真圓度與真直度
Measuring screw roundness and straightness.

配合特殊配件量測 With special accessories measurement

1. 螺絲與螺帽外六角之偏心率
Screw and hex nuts of eccentricity.
2. 外徑與內徑之同心度
Concentric outer and inner diameter.
3. 量測三通之真直度
To measurement three links of straightness.
4. 量測彎頭的直角度
To measurement of a straight the angle of bend.

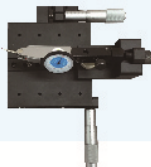
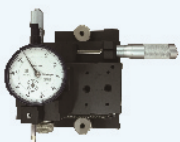



詮豐精密工具股份有限公司 Chuan Hong precision tool MFG.CO.,LTD

螺帽檢測規 (TPG)M Concentricity Thread Plug Gauges

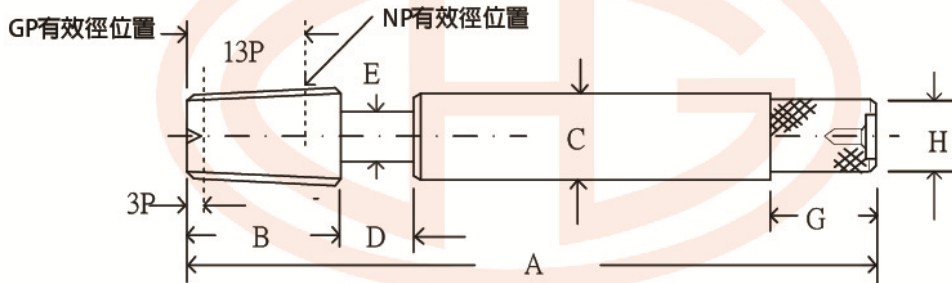

M 公制螺紋

單位: mm

規格 Specification	A 全長	B 牙長	C 柄長	D 頸長	G 長	GP=D2+X X=	NP=D2+X X=	斜度 X/1m/m	3P= m/m	13P= m/m	庫存
M 3 X 0.5	90	10.0	8	6.0	18.0	0	0.1090	0.02180	1.50	6.50	
M 4 X 0.7	90	14.0	8	6.0	18.0	0	0.1270	0.01814	2.10	9.10	
M 5 X 0.8	90	16.0	8	6.0	18.0	0	0.1340	0.01675	2.40	10.40	
M 6 X 1.0	90	20.0	8	6.0	18.0	0	0.1610	0.01610	3.00	13.00	
M 8 X 1.0	95	20.0	8	6.0	18.0	0	0.1610	0.01610	3.00	13.00	
M 8 X 1.25	95	25.0	8	6.0	18.0	0	0.1710	0.01368	3.75	16.25	
M 10 X 1.0	95	20.0	10	8.0	20.0	0	0.1610	0.01610	3.00	13.00	
M 10 X 1.25	95	25.0	10	8.0	20.0	0	0.1710	0.01368	3.75	16.25	
M 10 X 1.5	95	30.0	10	8.0	20.0	0	0.1910	0.01273	4.50	19.50	
M 12 X 1.0	110	20.0	13	9.0	25.0	0	0.1710	0.01710	3.00	13.00	
M 12 X 1.25	110	25.0	13	9.0	25.0	0	0.1910	0.01528	3.75	16.25	
M 12 X 1.5	110	30.0	13	9.0	25.0	0	0.2010	0.01340	4.50	19.50	
M 12 X 1.75	110	35.0	13	9.0	25.0	0	0.2110	0.01206	5.25	22.75	
M 14 X 1.0	120	20.0	13	9.0	25.0	0	0.1710	0.01710	3.00	13.00	
M 14 X 1.5	120	30.0	13	9.0	25.0	0	0.2010	0.01340	4.50	19.50	
M 14 X 2.0	120	40.0	13	9.0	25.0	0	0.2260	0.01130	6.00	26.00	
M 16 X 1.5	120	30.0	13	9.0	25.0	0	0.2010	0.01340	4.50	19.50	
M 16 X 2.0	120	40.0	13	9.0	25.0	0	0.2260	0.01130	6.00	26.00	
M 18 X 1.5	130	30.0	16	10.0	25.0	0	0.2010	0.01340	4.50	19.50	
M 18 X 2.0	130	40.0	16	10.0	25.0	0	0.2260	0.01130	6.00	26.00	
M 18 X 2.5	130	50.0	16	10.0	25.0	0	0.2380	0.00952	7.50	32.50	
M 20 X 1.5	130	30.0	16	10.0	25.0	0	0.2010	0.01340	4.50	19.50	
M 20 X 2.0	130	40.0	16	10.0	25.0	0	0.2260	0.01130	6.00	26.00	
M 20 X 2.5	130	50.0	16	10.0	25.0	0	0.2380	0.00952	7.50	32.50	
M 22 X 1.5	145	30.0	16	10.0	25.0	0	0.2010	0.01340	4.50	19.50	
M 22 X 2.0	145	40.0	16	10.0	25.0	0	0.2260	0.01130	6.00	26.00	
M 22 X 2.5	145	50.0	16	10.0	25.0	0	0.2380	0.00952	7.50	32.50	
M24 X 1.5	145	30.0	16	10.0	25.0	0	0.2110	0.01407	4.50	19.50	
M24 X 2.0	145	40.0	16	10.0	25.0	0	0.2380	0.01190	6.00	26.00	
M24 X 3.0	145	60.0	16	10.0	25.0	0	0.2790	0.00930	9.00	39.00	

※有●者備有庫存。
● means we have the item in stock.

※無庫存及特殊品，歡迎訂製。
No stock or special specifications are available on request.



詮豐精密工具股份有限公司 Chuan Hong precision tool MFG.CO.,LTD

螺帽檢測規 (TPG)UNC.UNF Concentricity Thread Plug Gauges

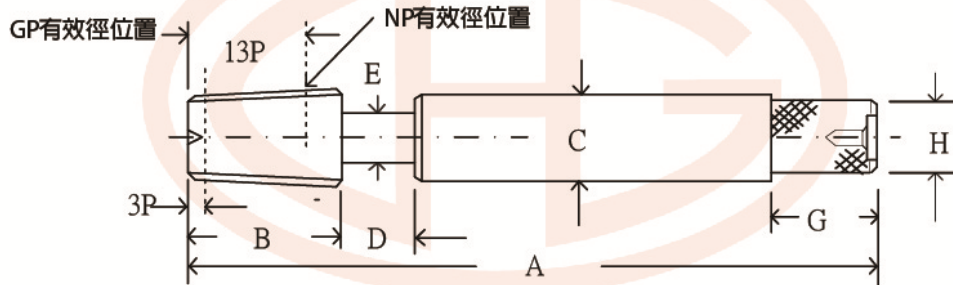

UNC美制粗螺紋

單位: mm

規格 Specification	A 全長	B 牙長	C 柄長	D 頸長	G 長	GP=D2+X X=	NP=D2+X X=	斜度 X/1m/m	3P= m/m	13P= m/m	庫存
1/4 - 20UNC	90	25.400	8.0	6.0	18.0	0	0.1240	0.00976	3.810	16.510	
5/16 - 18UNC	95	28.222	8.0	6.0	18.0	0	0.1340	0.00950	4.233	18.344	
3/8 - 16UNC	95	31.750	10.0	8.0	20.0	0	0.1440	0.00907	4.763	20.638	
7/16 - 14UNC	95	36.286	13.0	9.0	25.0	0	0.1540	0.00849	5.443	23.586	
1/2 - 13UNC	110	39.077	13.0	9.0	25.0	0	0.1650	0.00845	5.862	25.400	
9/16 - 12UNC	120	42.333	13.0	9.0	25.0	0	0.1730	0.00819	6.350	27.517	
5/8 - 11UNC	120	46.182	13.0	9.0	25.0	0	0.1830	0.00901	6.927	30.018	
3/4 - 10UNC	130	50.800	16.0	10.0	25.0	0	0.1950	0.00768	7.620	33.020	
7/8 - 9UNC	145	56.444	16.0	10.0	25.0	0	0.2080	0.00737	8.467	36.689	
1 - 8UNC	145	63.500	16.0	10.0	25.0	0	0.2230	0.00702	9.525	41.275	

UNF美制細螺紋

單位: mm

規格 Specification	A 全長	B 牙長	C 柄長	D 頸長	G 長	GP=D2+X X=	NP=D2+X X=	斜度 X/1m/m	3P= m/m	13P= m/m	庫存
1/4 - 28UNF	90	18.143	8.0	6.0	18.0	0	0.1080	0.01190	2.721	11.793	
5/16 - 24UNF	95	21.167	8.0	6.0	18.0	0	0.1220	0.01153	3.175	13.758	
3/8 - 24UNF	95	21.167	10.0	8.0	20.0	0	0.1240	0.01172	3.175	13.758	
7/16 - 20UNF	95	25.400	13.0	9.0	25.0	0	0.1370	0.01079	3.810	16.510	
1/2 - 20UNF	110	25.400	13.0	9.0	25.0	0	0.1420	0.01118	3.810	16.510	
9/16 - 18UNF	120	28.222	13.0	9.0	25.0	0	0.1490	0.01056	4.233	18.344	
5/8 - 18UNF	120	28.222	13.0	9.0	25.0	0	0.1520	0.01077	4.233	18.344	
3/4 - 16UNF	130	31.750	16.0	10.0	25.0	0	0.1640	0.01059	4.763	20.638	
7/8 - 14UNF	145	36.286	16.0	10.0	25.0	0	0.1780	0.00981	5.443	23.586	
1 - 12UNF	145	42.333	16.0	10.0	25.0	0	0.1920	0.00909	6.350	27.517	

※有●者備有庫存。
● means we have the item in stock.

※無庫存及特殊品，歡迎訂製。
No stock or special specifications are available on request.



詮豐精密工具股份有限公司 Chuan Hong precision tool MFG.CO.,LTD

螺帽內徑檢測規 (TMPG)M Concentricity Plug Gauges

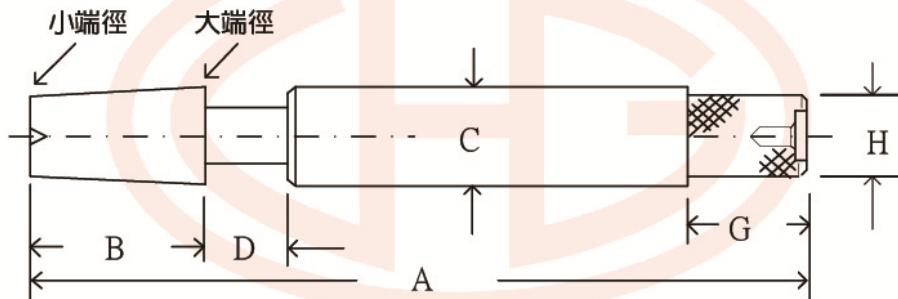

M 公制螺紋

單位: mm

規格 Specification	A 全長	B 牙長	C 柄長	D 頸長	G 長	MN 小端徑	MX 大端徑	斜度 X/1mm	內徑最小 mm	庫存 Stock
M 3 X 0.5	90	25	8	6.0	18.0	2.360	2.860	0.020	2.460	
M 4 X 0.7	90	25	8	6.0	18.0	3.140	3.640	0.020	3.240	
M 5 X 0.8	90	25	8	6.0	18.0	4.030	4.530	0.020	4.134	
M 6 X 1.0	90	25	8	6.0	18.0	4.820	5.320	0.020	4.920	
M 8 X 1.0	95	30	8	6.0	18.0	6.820	7.420	0.020	6.920	
M 8 X 1.25	95	30	8	6.0	18.0	6.540	7.140	0.020	6.650	
M 10 X 1.0	95	35	10	8.0	20.0	8.820	9.520	0.020	8.920	
M 10 X 1.25	95	35	10	8.0	20.0	8.540	9.240	0.020	8.650	
M 10 X 1.5	95	35	10	8.0	20.0	8.280	8.980	0.020	8.380	
M 12 X 1.0	110	40	13	9.0	25.0	10.800	11.600	0.020	10.920	
M 12 X 1.25	110	40	13	9.0	25.0	10.520	11.320	0.020	10.650	
M 12 X 1.5	110	40	13	9.0	25.0	10.260	11.060	0.020	10.380	
M 12 X 1.75	110	40	13	9.0	25.0	9.980	10.780	0.020	10.110	
M 14 X 1.0	120	45	13	9.0	25.0	12.800	13.700	0.020	12.920	
M 14 X 1.5	120	45	13	9.0	25.0	12.250	13.150	0.020	12.380	
M 14 X 2.0	120	45	13	9.0	25.0	11.720	12.620	0.020	11.840	
M 16 X 1.5	120	45	13	9.0	25.0	14.250	15.150	0.020	14.380	
M 16 X 2.0	120	45	13	9.0	25.0	13.720	14.620	0.020	13.840	
M 18 X 1.5	130	50	16	10.0	25.0	16.250	17.250	0.020	16.380	
M 18 X 2.0	130	50	16	10.0	25.0	15.720	16.720	0.020	15.840	
M 18 X 2.5	130	50	16	10.0	25.0	15.180	16.180	0.020	15.300	
M 20 X 1.5	130	50	16	10.0	25.0	18.250	19.250	0.020	18.380	
M 20 X 2.0	130	50	16	10.0	25.0	17.720	17.720	0.020	17.840	
M 20 X 2.5	130	50	16	10.0	25.0	17.180	18.180	0.020	17.300	
M 22 X 1.5	145	50	16	10.0	25.0	20.250	21.250	0.020	20.380	
M 22 X 2.0	145	50	16	10.0	25.0	19.720	20.720	0.020	19.840	
M 22 X 2.5	145	50	16	10.0	25.0	19.180	20.180	0.020	19.300	
M24 X 1.5	145	50	16	10.0	25.0	22.250	23.250	0.020	22.380	
M24 X 2.0	145	50	16	10.0	25.0	21.720	22.720	0.020	21.840	
M24 X 3.0	145	50	16	10.0	25.0	20.630	21.630	0.020	20.750	

※有●者備有庫存。
● means we have the item in stock.

※無庫存及特殊品，歡迎訂製。
No stock or special specifications are available on request.



詮豐精密工具股份有限公司 Chuan Hong precision tool MFG.CO.,LTD

螺帽內徑檢測規 (TMPG) UNC.UNF Concentricity Plug Gauges

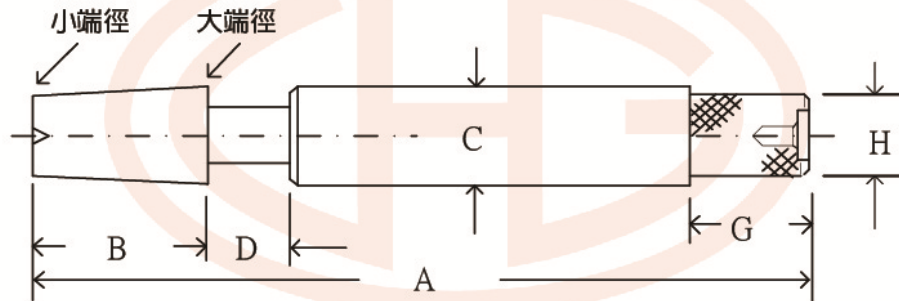

UNC美制粗螺紋

單位: mm

規格 Specification	A 全長	B 牙長	C 柄長	D 頸長	G 長	MN 小端徑	MX 大端徑	斜度 X/1mm	內徑最小 mm	庫存 Stock
1/4 - 20UNC	90	25	8.0	6.0	18.0	4.880	5.380	0.020	4.980	
5/16 - 18UNC	95	30	8.0	6.0	18.0	6.310	6.910	0.020	6.410	
3/8 - 16UNC	95	35	10.0	8.0	20.0	7.700	8.400	0.020	7.810	
7/16 - 14UNC	95	35	13.0	9.0	25.0	9.030	9.730	0.020	9.150	
1/2 - 13UNC	110	40	13.0	9.0	25.0	10.470	11.270	0.020	10.590	
9/16 - 12UNC	120	45	13.0	9.0	25.0	11.880	12.780	0.020	12.000	
5/8 - 11UNC	120	45	13.0	9.0	25.0	13.260	14.160	0.020	13.380	
3/4 - 10UNC	130	50	16.0	10.0	25.0	16.180	17.180	0.020	16.300	
7/8 - 9UNC	145	50	16.0	10.0	25.0	19.050	20.050	0.020	19.170	
1 - 8UNC	145	50	16.0	10.0	25.0	21.850	22.850	0.020	21.970	

UNF美制細螺紋

單位: mm

規格 Specification	A 全長	B 牙長	C 柄長	D 頸長	G 長	MN 小端徑	MX 大端徑	斜度 X/1m/m	內徑最小 mm	庫存 Stock
1/4 - 28UNF	90	25	8.0	6.0	18.0	5.270	5.770	0.020	5.370	
5/16 - 24UNF	95	30	8.0	6.0	18.0	6.690	7.290	0.020	6.790	
3/8 - 24UNF	95	35	10.0	8.0	20.0	8.280	8.980	0.020	8.380	
7/16 - 20UNF	95	35	13.0	9.0	25.0	9.620	10.320	0.020	9.740	
1/2 - 20UNF	110	40	13.0	9.0	25.0	11.210	12.010	0.020	11.330	
9/16 - 18UNF	120	45	13.0	9.0	25.0	12.640	13.540	0.020	12.760	
5/8 - 18UNF	120	45	13.0	9.0	25.0	14.230	15.130	0.020	14.350	
3/4 - 16UNF	130	50	16.0	10.0	25.0	17.210	18.210	0.020	17.330	
7/8 - 14UNF	145	50	16.0	10.0	25.0	20.140	21.140	0.020	20.260	
1 - 12UNF	145	50	16.0	10.0	25.0	22.990	23.990	0.020	23.110	

※有●者備有庫存。
● means we have the item in stock.

※無庫存及特殊品，歡迎訂製。
No stock or special specifications are available on request.



詮豐精密工具股份有限公司 Chuan Hong precision tool MFG.CO.,LTD

拉力測試棒 (BD)M Thread Pull Mandrel

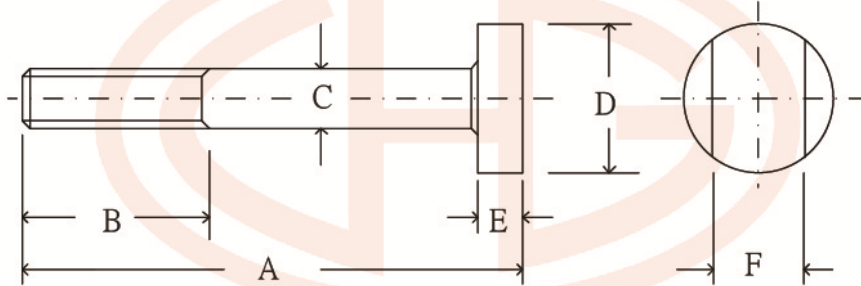

M 公制螺紋

單位: mm

規格 Specification	A	B	C	D	E	F	螺紋外徑 OD	螺紋中徑 PD	庫存 Stock
M 3 X 0.5	55	12	3	7.0	5	5.5	2.901-2.874	2.675-2.615	
M 4 X 0.7	55	12	4	7.0	5	5.5	3.873-3.838	3.545-3.474	
M 5 X 0.8	60	12	5	8.0	5	6.0	4.864-4.826	4.480-4.405	
M 6 X 1.0	66	20	6	11.8	6	9.9	5.794-5.839	5.350-5.260	
M 8 X 1.0	75	25	8	14.8	8	12.9	7.819-7.760	7.350-7.260	
M 8 X 1.25	75	25	8	14.8	8	12.9	7.818-7.768	7.188-7.093	
M 10 X 1.0	80	35	10	19.8	10	16.9	9.839-9.794	9.350-9.260	
M 10 X 1.25	80	35	10	19.8	10	16.9	9.818-9.768	9.188-9.093	
M 10 X 1.5	80	35	10	19.8	10	16.9	9.791-9.731	9.026-8.966	
M 12 X 1.0	85	35	12	21.8	12	18.8	11.839-11.789	11.350-11.255	
M 12 X 1.25	85	35	12	21.8	12	18.8	11.850-11.830	11.188-11.098	
M 12 X 1.5	85	35	12	21.8	12	18.8	11.791-11.731	11.026-10.926	
M 12 X 1.75	85	35	12	21.8	12	18.8	11.767-11.717	10.863-10.753	
M 14 X 1.0	95	40	14	24.8	14	21.8	13.839-13.794	13.350-13.260	
M 14 X 1.5	95	40	14	24.8	14	21.8	13.791-13.732	13.026-12.914	
M 14 X 2.0	95	40	14	24.8	14	21.8	13.752-13.702	12.701-12.651	
M 16 X 1.5	102	45	16	26.8	16	23.8	15.791-15.741	15.026-14.956	
M 16 X 2.0	102	45	16	26.8	16	23.8	15.752-15.682	14.701-14.576	
M 18 X 1.5	110	50	18	30.8	18	26.5	17.791-17.741	17.029-16.914	
M 18 X 2.0	110	50	18	30.8	18	26.5	17.761-17.682	16.701-16.576	
M 18 X 2.5	110	50	18	30.8	18	26.5	17.706-17.656	16.376-16.244	
M 20 X 1.5	115	50	20	33.8	20	29.5	19.780-19.730	19.026-18.914	
M 20 X 2.0	115	50	20	33.8	20	29.5	19.780-19.730	18.701-18.576	
M 20 X 2.5	115	50	20	33.8	20	29.5	19.706-19.623	18.376-18.244	
M 22 X 1.5	122	55	22	36.8	22	31.5	21.790-21.740	21.026-20.914	
M 22 X 2.0	122	55	22	36.8	22	31.5	21.780-21.730	20.701-20.611	
M 22 X 2.5	122	55	22	36.8	22	31.5	21.706-21.623	20.376-20.244	
M24 X 1.5	165	60	24	39.8	24	35.5	23.791-23.741	23.026-22.908	
M24 X 2.0	165	60	24	39.8	24	35.5	23.780-23.730	22.701-22.569	
M24 X 3.0	165	60	24	39.8	24	35.5	23.670-23.620	22.051-21.891	

※有●者備有庫存。
● means we have the item in stock.

※無庫存及特殊品，歡迎訂製。
No stock or special specifications are available on request.



詮豐精密工具股份有限公司 Chuan Hong precision tool MFG.CO.,LTD

拉力測試棒 (BD)UNC.UNF Thread Pull Mandrel

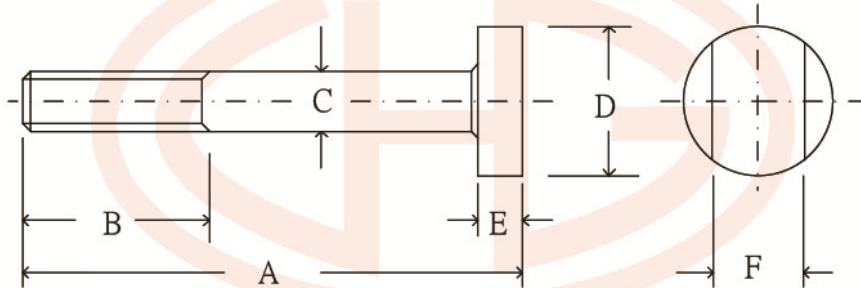

UNC美制粗螺紋

單位: mm

規格 Specification	A	B	C	D	E	F	螺紋外徑 OD	螺紋中徑 PD	庫存 Stock
1/4 - 20UNC	80	20	6.3	12.5	7	11.0	6.196-6.145	5.524-5.454	
5/16 - 18UNC	85	22	7.9	14.5	8	12.5	7.772-7.717	7.020-6.945	
3/8 - 16UNC	90	25	9.5	16.5	10	14.1	9.346-9.287	8.493-8.410	
7/16 - 14UNC	92	28	11.1	19.5	12	17.3	10.916-10.851	9.933-9.846	
1/2 - 13UNC	102	32	12.7	21.5	13	19.0	12.493-12.424	11.430-11.336	
9/16 - 12UNC	105	35	14.3	25.5	15	22.0	14.070-13.998	12.913-12.814	
5/8 - 11UNC	105	38	15.9	27.5	16	23.5	15.644-15.568	14.376-14.273	
3/4 - 10UNC	115	46	19.0	32.5	20	28.0	18.804-18.723	17.399-17.288	
7/8 - 9UNC	122	53	22.2	37.5	22	33.0	21.923-21.872	20.391-20.272	
1 - 8UNC	165	60	25.4	41.5	26	37.5	25.070-25.019	23.337-23.208	
1 1/8 - 7UNC	175	66	28.6	48.0	29	42.0	28.263-28.159	26.217-26.081	
1 1/4 - 7UNC	182	72	31.7	54.0	32	47.0	31.438-31.334	29.392-29.254	

UNF美制細螺紋

單位: mm

規格 Specification	A	B	C	D	E	F	螺紋外徑 OD	螺紋中徑 PD	庫存 Stock
1/4 - 28UNF	80	20	6.3	12.5	7	11.0	6.226-6.185	5.760-5.698	
5/16 - 24UNF	85	22	7.9	14.5	8	12.5	7.800-7.755	7.249-7.181	
3/8 - 24UNF	90	25	9.5	16.5	10	14.1	9.388-9.343	8.836-8.763	
7/16 - 20UNF	92	28	11.1	19.5	12	17.3	10.958-10.907	10.287-10.208	
1/2 - 20UNF	102	32	12.7	21.5	13	19.0	12.545-12.494	11.874-11.794	
9/16 - 18UNF	105	35	14.3	25.5	15	22.0	14.122-14.067	13.370-13.285	
5/8 - 18UNF	105	38	15.9	27.5	16	23.5	15.710-15.655	14.958-14.870	
3/4 - 16UNF	115	46	19.0	32.5	20	28.0	18.871-18.812	18.018-17.923	
7/8 - 14UNF	122	53	22.2	37.5	22	33.0	22.029-21.964	21.064-20.943	
1 - 12UNF	165	60	25.4	41.5	26	37.5	25.183-25.111	24.025-23.915	
1 1/8 - 12UNF	175	66	28.6	48.0	29	42.0	28.358-28.286	27.200-27.087	
1 1/4 - 12UNF	182	72	31.7	54.0	32	47.0	31.533-31.461	30.375-30.259	

※有●者備有庫存。
● means we have the item in stock.

※無庫存及特殊品，歡迎訂製。
No stock or special specifications are available on request.

螺紋規與螺絲攻之故障排除

產品名稱	正常使用	異常狀況	原因	改善方法	使用工具	備註
平行螺紋 栓規	GO通， NOGO不通	GO不通， NOGO不通	中徑太小	加大螺帽中徑 加大螺絲攻	螺帽檢測規 判斷精度	
		GO通， NOGO也通	中徑太大	減小螺帽中徑 減小螺絲攻	螺帽檢測規 判斷精度	
		GO不通， 但NOGO通	中徑太大 小徑太小	更換牙刀 更換螺絲攻	螺帽檢測規 判斷精度	山形角度變形
平行螺紋 環規	GO通， NOGO不通	GO不通， NOGO不通	中徑太大	螺絲中徑減小	用三線規與 標準規比測	
		GO通， NOGO也通	中徑太小	螺絲中徑加大	用三線規與 標準規比測	
		GO不通， 但NOGO通	中徑太小 小徑太大	更換車牙刀具	投影機或工 具顯微鏡	山形角度變形
錐度螺紋 栓規 標準規SG 中徑規WG	SG與WG量 測於上公差 與下公差範 圍內	SG,WG未到 Min	中徑太小	加大中徑	SG配合WG 量測	
		SG,WG超出 Max	中徑太大	減小中徑	SG配合WG 量測	
		SG正常,WG 超出Max	中徑太大 小徑太小	螺紋變形 更換刀具		山形角度變形
錐度螺紋 栓規 標準規RSG 中徑規RWG	SG與WG量 測於上公差 與下公差範 圍內	SG,WG未到 Max	中徑太大	減小中徑	RSG配合 RWG量測	
		SG,WG超出 Min	中徑太小	加大中徑	RSG配合 RWG量測	
		SG正常,WG 超出Min	中徑太小 小徑太大	螺紋變形 更換刀具		山形角度變形
平行絲攻	攻牙之工件牙 面光滑	牙面粗糙有 毛翹	切削角錯 誤刀不利	整修刀具	磨刀機：絲攻 溝槽整修機	
	攻牙之工件精 度符合標準	GO,NOGO 不標準	同平行螺 紋栓規	參考上列平行 螺紋栓規	螺帽檢測規	
錐度絲攻	攻牙之工件 精度在Max 與Min之間	精度超出 Max	中徑太大	調整絲攻攻牙 深度(太深)	管用螺紋栓規	牙長不夠或太 長時，更換螺 絲攻
		精度達不到 Min	中徑太小	調整絲攻攻牙 深度(太淺)	管用螺紋栓規	



詮豐標誌 品質保證
CHUAN HONG is a quality guarantee.

詮豐精密工具股份有限公司
CHUAN HONG PRECISION TOOL MFG. CO., LTD.

台灣高雄市田寮區新興里公館19號

Address NO.19 Gongguan.Sinsing Village,
Tianliao.Dist,Kaohsiung City,
Taiwan

Tel 886-7-6381281 Fax 886-7-6381103

Email chggauge@gmail.com

上海詮豐工具有限公司
SHANG HAI CHUAN HONG TOOL MFG. CO., LTD.

上海市嘉定區江橋鎮紅光村凌志路108號

Address No.108 LingZhi Rd. Hongguang Village,
Jiangqiao Town, Jiading District, Shanghai

Tel 86-21-59136471 Fax 86-21-59136809

Email shqfpt@126.com

代理商：
AGENT：